

# Motor Valve

## GS 1 series

# 8036

## DN 15 up to DN 150

SCHUBERT & SALZER  
**CONTROL SYSTEMS**

Motor valve for control and switching of neutral through to highly aggressive media in process engineering, chemical industries and for plant equipment.

- Space saving wafer type construction
- Lowest possible weight (especially in larger sizes)
- Low operation noise level (quiet operation)
- Control of high differential pressures with small actuators
- Fast response time

### Technical Information

Body material	flangeless, wafer type construction dimensions acc. DIN EN 558-1 series 20 for flanges acc. DIN EN 1092-1 form B more versions see data-sheet 8036-GS3	
Nominal sizes	DN 15 up to DN 150	
Nominal pressure	PN 40 acc. DIN 2401 also for flanges PN 10 up to PN 25	
Fluid temperature	body 1.0570: -10°C up to +300°C body 1.4571: -60°C up to +350°C	
Rangeability	30 : 1	
Leakage (% of Kvs)	Disc pair Carbon-stainless steel < 0,0001	Disc pair STN 2 < 0,001

K<sub>vs</sub>-values see data sheet 8001.



### Materials

Body	carbon steel 1.0570 /1.0619	stainless steel 1.4571 /1.4581
Head section	carbon steel 1.0570 /1.0619	stainless steel 1.4571 /1.4581
Packing	PTFE (carbon filled), spring 1.4310	
Actuating stem	stainless steel, roller burnished	
Bellow	stainless steel 1.4571	
Fixed disc	stainless steel 1.4571, plated	STN2-disc
Sliding disc	standard: special carbon material	STN2-disc
Coupling ring for disc	stainless steel 1.4581	

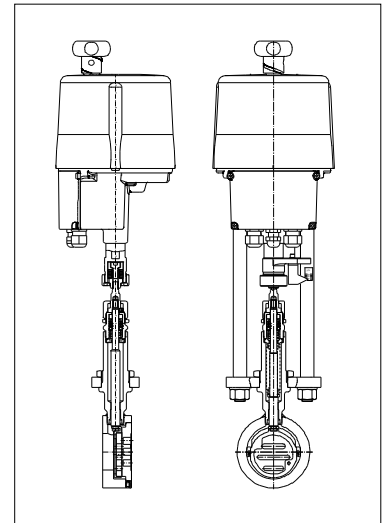

# Motor Valve 8036-GS1

## Actuator with Electronic Positioner

### Technical Information

Driving force	2,3 kN
Type of duty (according IEC-34)	S2 30min S4 - 1200 c/h 50% ED
Power connections	24 V DC 24 V AC 110/120 V AC 230 V AC
Ambient temperature	-20°C up to +60°C
Mounting position	choice horizontal or vertical actuator only
Protection class (DIN 60529)	IP 65
max. Power consumption	30 Watt
Set point range	adjustable 0 - 20 mA, 0 - 10 V
Feed back	adjustable 0 - 20 mA, 0 - 10 V
Self Monitoring	torque, set point, temperature
Diagnostic function	storage of motor and total service life, number of motor starts, etc.
Valve adaptation	automatic stroke adjustment to suit valve limits

### Stroking Time (sec.)

DN	Stroking speed for the complete stroke		
	0,45 mm/s (50%)	0,67 mm/s (75%)	0,9 mm/s (100%)
15 - 40	13,9	9,3	6,9
50 - 80	18,4	12,3	9,2
100 - 150	19,5	13,1	9,7

 = Standard

### Options

2 additional stroke limit switches	free adjustable volt free contacts (open/close)
Heater	anti condensation heater
Process controller	PI - process controller integrated in the actuator
Fair Safe Protection	via battery pack open or closed
Local control	mounted on the actuator
Communication software	by use of data care to configure actuator

### Admissible Differential Pressures

DN	max. differential pressure (bar)			
	carbon - stainless steel coated control	carbon - stainless steel coated on - off	STN2 control	STN2 on - off
15	40	40	40	40
20	40	40	40	40
25	40	40	40	40
32	40	40	40	40
40	40	40	27	27
50	40	40	27	40
65	40	40	22	38
80	34	40	13	22
100	21	24	8	13
125	14	16	5,5	9
150	11	16	4	8

# Motor Valve 8036-GS1

**Actuator without Electronic Positioner**  
 (function: open/close or 3-step-drive)

## Technical Information

Driving force	1 kN, 2 kN, 4,5 kN
Type of duty (according VDE 0530)	S2 30min S4 - 1200 c/h 50%ED
Power connections	24 V AC 110/120V AC 230 V AC
Ambient temperature	-20°C bis +80°C (S2) / -20°C bis +60°C (S4)
Mounting position	choice horizontal or vertical actuator only
Protection class (EN 60529)	IP 65
max. Power consumption	1 kN: 26W, 2 kN: 30W , 4,5kN: 47 W
Actuator protection	torque switch

## Options

2 additional stroke limit switches	free adjustable volt free contacts (open/close)
Heater	anti condensation heater
Feed back 4-20 mA	in 2-wire or 3-wire design
Local control	mounted key pad on actuator

## Stroking Time (sec.)

DN	Stroking speed for the complete stroke		
	1 kN	2 kN	4,5 kN
15 - 40	25	25	12,5
50 - 80	33	33	16,5
100 - 150	35	35	17,5

(other regulating speeds on request)

## Admissible Differential Pressures

DN	max. differential pressure (bar)					
	disc - pair carbon stainless steel coated			disc - pair STN2		
	1 kN	2 kN	4,5 kN	1 kN	2 kN	4,5 kN
15	40	40	40	40	40	40
20	40	40	40	40	40	40
25	40	40	40	36	40	40
32	40	40	40	26	40	40
40	39	40	40	18	27	27
50	26	40	40	11	23	40
65	22	40	40	9	19	38
80	14	29	40	5	11	22
100	8,5	18	24	3	7	13
125	6	12	16	2	4,5	9
150	4,5	9,5	16	1,5	3,5	8



# Motor Valve 8036-GS1

## Dimensions and Weights

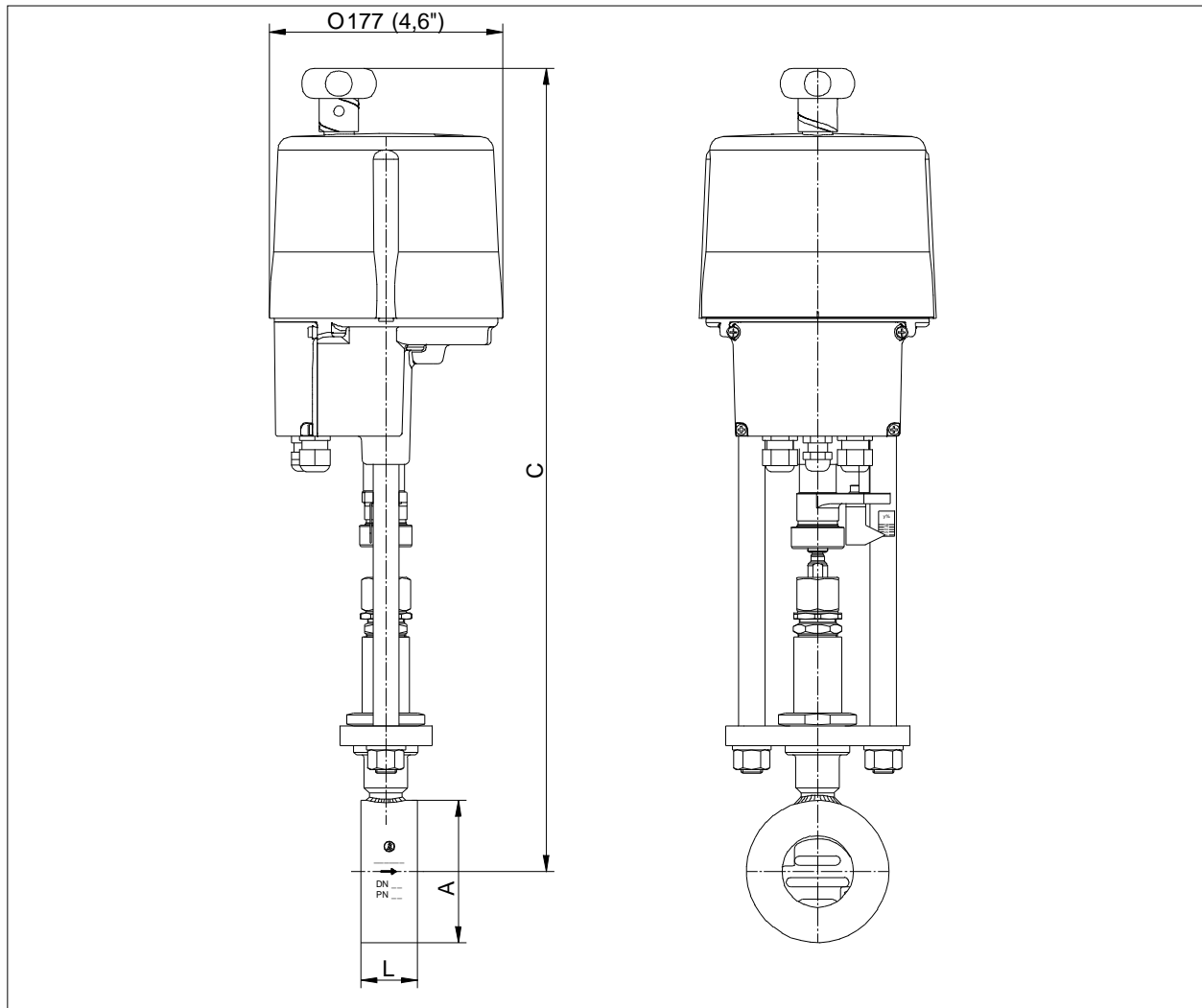

DN	øA mm	C mm	L mm	Stroke mm	Weight kg
15	53	580	33	6	7,6
20	62	585	33	6	7,7
25	72	590	33	6	7,8
32	82	595	33	6	7,9
40	92	600	33	6	8
50	108	610	43	8	9,2
65	127	620	46	8	9,7
80	142	625	46	8	10,4
100	164	640	52	8,5	11,6
125	194	655	56	8,5	13,4
150	219	670	56	8,5	15,3