



## TABLE OF CONTENTS

### Designation code

How to read sensor designations	3
---------------------------------	---

### Circuit diagrams

Connection according to EN 60947-5-2	4
--------------------------------------	---

### Functional description

Operating mode of magnetoresistive sensors	5
--	---

### Applications

Application areas of magnetoresistive sensors	6
---	---

### Sensors

Cylinder G10	7
Cylinder M12	8
Cylinder M18	10

### Product overview

All sensors at a glance	12
-------------------------	----



## NOTES

---



# MAGNETORESISTIVE SENSORS

## DESIGNATION CODE

Example: **K J 10 - M 30 M B 45 - D P S - V1 - X0000**

1	2	3	4	5	6	7	8	9	10	11	12

### 1 = Working principle

<b>A</b>	Acoustic
<b>B</b>	Acceleration sensor
<b>C</b>	Capacitive
<b>D</b>	Strain gauge sensor
<b>H</b>	Hall-effect
<b>J</b>	Inductive
	<b>JR</b> Inductive ring
	<b>JF</b> Inductive surface
	<b>JG</b> Inductive slot
	<b>JD</b> Metalface
<b>M</b>	Magnetoresistive
<b>N</b>	Inclination sensor
<b>R</b>	Reed-contact
<b>W</b>	Angle sensor

### 2 = Switching distance / range

### 3 = Design

<b>D</b>	Ring housing
<b>G</b>	Cylindrical housing without thread
<b>M</b>	Cylindrical housing with metrical thread
<b>Q</b>	Square housing

### 4 = Housing diameter / edge length

### 5 = Housing material

<b>A</b>	Aluminium
<b>E</b>	Stainless steel
<b>K</b>	Plastic
<b>M</b>	Brass, nickel plated
<b>T</b>	PTFE

### 6 = Installation

<b>B</b>	Shielded
<b>N</b>	Non shielded

### 7 = Tube length

### 8 = Operating voltage

<b>AZ</b>	AC alternating current voltage
<b>D</b>	DC direct current voltage
<b>VZ</b>	AC/DC all voltages

### 9 = Type of output signal

<b>AN</b>	Analog	<b>ANI</b>	Current output
		<b>ANU</b>	Voltage output
<b>CAN</b>	CAN-bus interface		
<b>N</b>	NPN		
<b>NA</b>	Namur		
<b>P</b>	PNP		
<b>Z</b>	Two wire		

### 10 = Function

<b>A</b>	Changeover
<b>I</b>	Impulse output
<b>Ö</b>	N.C.
<b>S</b>	N.O.
<b>U</b>	Switchable

### 11 = Connection

<b>V1</b>	M8 screw-/snap-in
<b>V2</b>	M12 metal
<b>V2/1</b>	M12 plastic
<b>V3</b>	M5 metal
<b>V4</b>	Amphenol Tuchel
<b>V6</b>	Brad Harrison
<b>V7</b>	Valve connector type A
<b>V8</b>	M8 snap-in only
<b>V9</b>	Torson
<b>V10</b>	Valve connector type C
<b>V11</b>	AC connector 1/2" UNF
<b>V12</b>	M18 plastic
<b>VE</b>	Euchner connector
<b>RS232</b>	Data interface
<b>PG</b>	Thread joint PG
<b>Mxx</b>	Thread joint metrical

others as requested

### 12 = Additional marks

<b>AM</b>	Sensing face in centre
<b>FE</b>	Reduction 1 to steel / iron
<b>HT</b>	High temperature
<b>NF</b>	Reduction 1 to nonferrous metal
<b>SF</b>	Weld field immune
<b>T</b>	Enlarged temperature range
<b>W</b>	Angled sensing face / angled cable exit
<b>X</b>	Customized design with detailed description



# MAGNETORESISTIVE SENSORS

## CIRCUIT DIAGRAMS

Circuit diagram for	Cable / clamp connection	Connector V1 ... V9
DPI Pulse generator PNP		
DNI Pulse generator NPN		
DPI-D9 Pulse generator PNP 90°		
DNI-D9 Pulse generator NPN 90°		
DPI-D Pulse generator PNP L / H		
DNI-D Pulse generator PNP L / H		



## FUNCTIONAL DESCRIPTION

Magnetoresistive sensors are used for measuring rotational speed, directions, distances and angles as well as for controlling mechanical processes. They are of special importance for applications in which inductive sensors are not appropriate due to high switching frequencies or enlarged operating temperatures. Magnetoresistive sensors measure speed etc. on moving gear wheels made of ferromagnetic material (passive targets) and on rotating wheels with alternating magnetic poles (active targets). The operating mode of these sensors is based on a voltage fluctuation in the inside of the sensor caused by an alternating magnetic field.

**Passive targets:** For the detection of passive targets an internal permanent magnet generates a constant magnetic field in and around the sensor. On the sensor a voltage is impressed on. If a ferromagnetic object (toothed wheel) is moved in the magnetic field, it deflects the magnetic field lines (see illstr. 1). This causes a voltage fluctuation in the sensor. This analog fluctuation passes trigger and amplifier, the sensor provides a digital output signal.

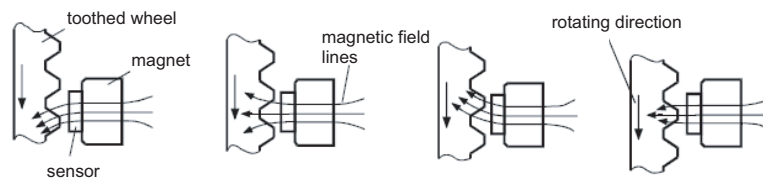

Illustration 1: Deflection of magnetic field lines on the passive target

### Active targets:

Here the target itself generates the magnetic field. There is no need of a permanent magnet (see illstr. 2). On the sensor a voltage is impressed on. Due to the rotation of the target the poles and the magnetic field lines on front of the sensor are changing. This leads to a voltage fluctuation in the sensor. The deviation of the signal excites an output pulse.

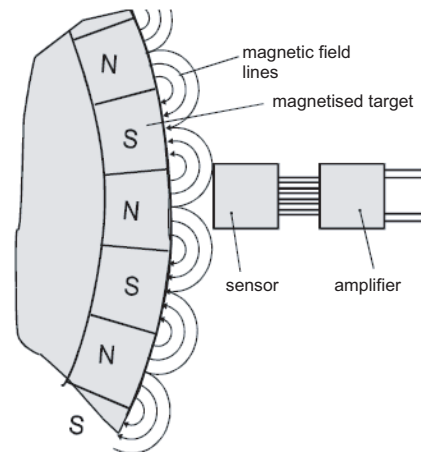

Illustration 2: Changing of the magnetic field lines on the active target

## Specific characteristics

Minimum changes of the magnetic field, for example caused by a gear wheel, can be detected by our version DPI up to a frequency of 20kHz and a switching distance of 2,5mm. The output signal of a magnetoresistive sensor does not depend on the speed. The PNP-output allows a maximum ampacity of 200mA respectively 2 x 100mA. Magnetoresistive sensors work independently of vibrations and provide a high electromagnetic compatibility. They are compatible to inductive proximity switches and optionally available with enlarged temperature range of maximum 120°C.



# MAGNETORESISTIVE SENSORS

## APPLICATIONS

### Speed measuring

A permanent magnet in the sensor generates a constant magnetic field. The MR-element, which is situated in front of the magnet in the sensing head, collects the magnetic field and is biased by it. A ferromagnetic gear wheel rotating in front of the sensing head causes a deflection of the magnetic field lines due to the alternation of tooth and valley. The MR-elements register these changes and increase or decrease their resistor depending on the alignment of the field lines. The result is a voltage fluctuation in the sensor. The switching distance  $d$  is the space between the sensor face and the face of the teeth. Measurement is realised centrally to the axis of the permanent magnet.

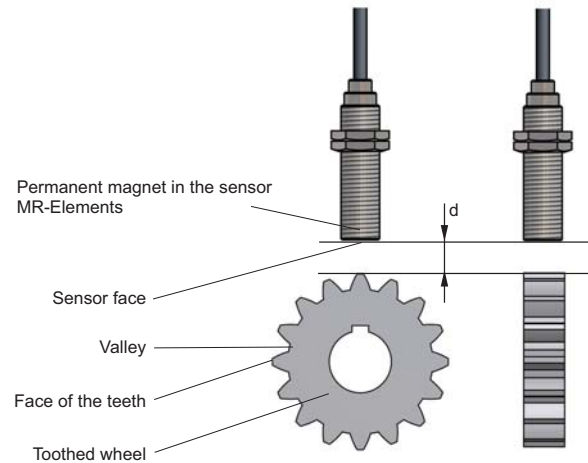

### Detection of rotating direction

Pulsotronic magnetoresistive sensors in design DPI-D9 and DPI-D are able to detect the rotating direction. Due to two elements in the threaded tube the sensors DPI-D9 provide two phase shifted rectangular signals. At left handed rotation signal 1 is leading ahead of signal two. At right handed rotation signal 1 is lagging behind signal 2. Thus this version can for instance replace an incremental encoder. The version DPI-D evaluates these signals directly in the sensor: Depending on the rotating direction the sensor exits a permanent HIGH- or LOW pulse. The frequency output is realised by a separate connection. One possible application is for example a speed measurement with detection of the rotating direction: signal 1 indicates the speed, signal 2 the direction by HIGH or LOW.

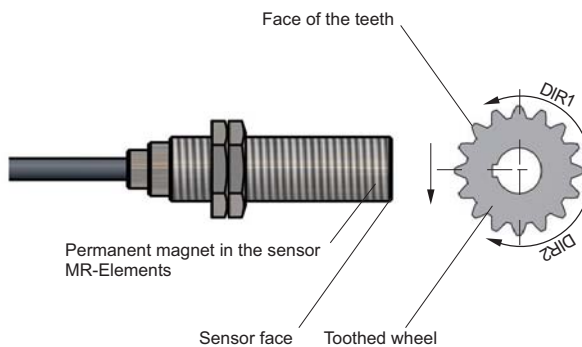

### End-of-travel detection

For this kind of applications the permanent magnet is situated outside of the sensor. Measurement is realised by the changings of the magnetic field in front of the sensing head. Similar to speed measuring and the detection of the rotating direction the working principle is based on a voltage fluctuation in the sensor due to an external magnetic field. Hereby GMR-elements are used that are able to detect even smallest magnetic fields. Depending on the distance between permanent magnet and sensor the flux density in the MR-element changes. This leads to a voltage fluctuation in the sensor because of the variation of the resistors.

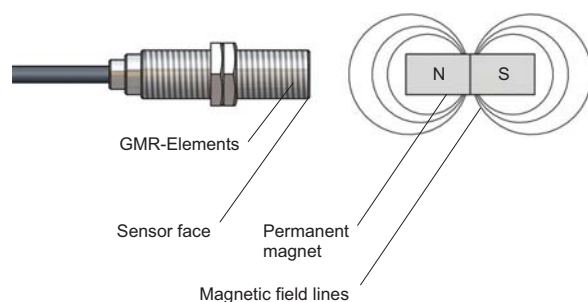



## MAGNETORESISTIVE SENSORS

### CYLINDER G10

#### Technical data

<b>Article number</b>	<b>Designation</b>
08330000048	<b>KM0,5-G10KB13-ANU-X0101</b> (compatible to FP 210 from Infineon)
<b>Mounting</b>	shielded
<b>Switching distance</b>	0,5mm (+/- 0,2mm)
<b>Reference target</b>	transmitter wheel module 1
<b>Output signal</b>	analog, sinusoidal
<b>Operating voltage <math>U_b</math></b>	4,1 ... 6,2V DC
<b>Max. output current</b>	+ / - 4mA
<b>Usable switching frequency</b>	50.000Hz
<b>Operating temperature <math>T_a</math></b>	-40°C ... +85°C
<b>DC-Offset</b>	$U_{o-dyn} = 2,50V \pm 10\%$ ( $U_B$ 0 5,00V)
<b>Protection class</b>	IP67
<b>Housing material</b>	Terez 7500 GF35 H
<b>Connection</b>	3 x PIN (L = 13,5mm)

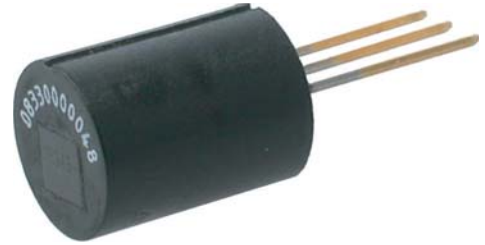

#### Connector pin assignment

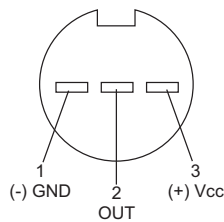

#### Dimensions

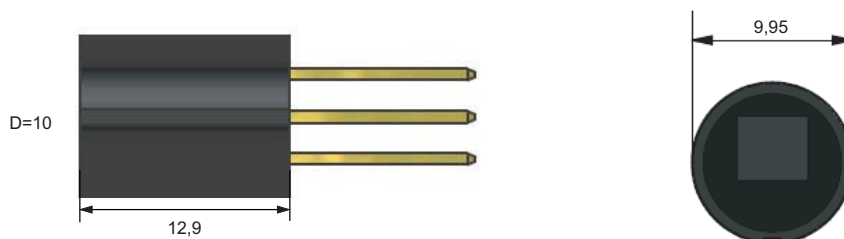

all data in mm



# MAGNETORESISTIVE SENSORS

## CYLINDER M12

### General data

<b>Mounting</b>	shielded
<b>Switching distance</b>	1,5mm
<b>Output signal</b>	rectangular pulse
<b>Operating voltage <math>U_b</math></b>	10 ... 30V DC
<b>Voltage drop <math>U_d</math></b>	$\leq 1,5V$
<b>Module</b>	0,8
<b>Off-state current <math>I_o</math></b>	$\leq 10mA$
<b>Operating temperature <math>T_a</math></b>	-25°C ... +70°C
<b>Temperature drift</b>	$\leq 10\%$ (Sr)
<b>Protection class</b>	IP67
<b>EMV-standard</b>	according to IEC 60947-5-2
<b>Switching state</b>	LED
<b>Housing material</b>	brass, nickel-plated *
<b>Front cap</b>	PA 6.6



\* On request also with stainless steel housing and enlarged temperature range up to 120 °C.

The selection chart for these sensors is shown on the following page.

### Dimensions

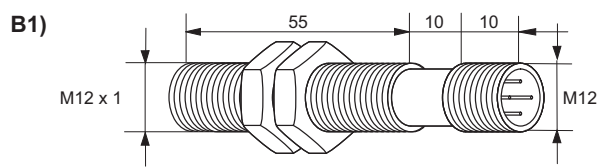
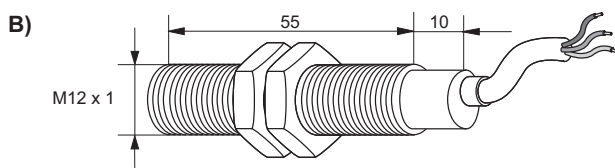
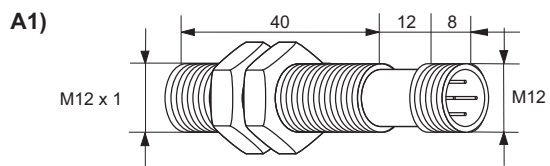
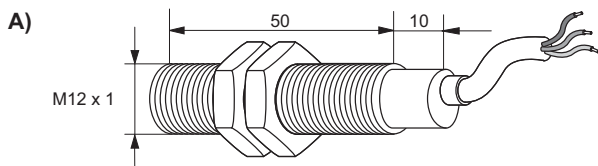

all data in mm



# MAGNETORESISTIVE SENSORS

## CYLINDER M12

### Selection chart

Article number	Designation standard Output signal (1)	Output signal pulse	Usable Switching frequency	Max. load current * = per output	Connection	Drawing (previous page)
0833000017	<b>KM1,5-M12MB-DPI</b>	<b>PNP</b>	0 - 20.000Hz	≤ 200mA	cable	A
08330000117	<b>KM1,5-M12MB-DNI</b>	<b>NPN</b>	0 - 20.000Hz	≤ 200mA	cable	A
08330000045	<b>KM1,5-M12MB-DPI-V2</b>	<b>PNP</b>	0 - 20.000Hz	≤ 200mA	connector	A1
08330000145	<b>KM1,5-M12MB-DNI-V2</b>	<b>NPN</b>	0 - 20.000Hz	≤ 200mA	connector	A1

Cable: 2m cable PVC 3 x 0,34mm<sup>2</sup>  
Connector: connector M12 4-pole

(1) f out

	Designation Phase quadrature Output signal (2)					
08330000011	<b>KM1,5-M12MB-DPI-D9</b>	<b>PNP</b>	2 - 20.000Hz	≤ 100mA*	cable	B
08330000033	<b>KM1,5-M12MB-DNI-D9</b>	<b>NPN</b>	2 - 20.000Hz	≤ 100mA*	cable	B
08330000039	<b>KM1,5-M12MB-DPI-D9-V2</b>	<b>PNP</b>	2 - 20.000Hz	≤ 100mA*	connector	B1
08330000139	<b>KM1,5-M12MB-DNI-D9-V2</b>	<b>NPN</b>	2 - 20.000Hz	≤ 100mA*	connector	B1

Cable: 2m cable PVC 4 x 0,25mm<sup>2</sup>  
Connector: connector M12 4-pole

(2) f out 1   
f out 2

	Designation Low/High flank Output signal (3)					
08330000016	<b>KM1,5-M12MB-DPI-D</b>	<b>PNP</b>	2 - 20.000Hz	≤ 100mA*	cable	B
08330000116	<b>KM1,5-M12MB-DNI-D</b>	<b>NPN</b>	2 - 20.000Hz	≤ 100mA*	cable	B
08330000015	<b>KM1,5-M12MB-DPI-D-V2</b>	<b>PNP</b>	2 - 20.000Hz	≤ 100mA*	connector	B1
08330000115	<b>KM1,5-M12MB-DNI-D-V2</b>	<b>NPN</b>	2 - 20.000Hz	≤ 100mA*	connector	B1

Cable: 2m cable PVC 4 x 0,25mm<sup>2</sup>  
Connector: connector M12 4-pole

(3) f out 1   
f out 2

Other cable lengths as requested.



## MAGNETORESISTIVE SENSORS

### CYLINDER M18

#### General data

<b>Mounting</b>	shielded
<b>Switching distance</b>	2,5mm
<b>Output signal</b>	rectangular pulse
<b>Operating voltage <math>U_b</math></b>	10 ... 30V DC
<b>Voltage drop <math>U_d</math></b>	$\leq 1,5V$
<b>Module</b>	1,5
<b>Off-state current <math>I_0</math></b>	$\leq 10mA$
<b>Operating temperature <math>T_a</math></b>	-25°C ... +70°C
<b>Temperature drift</b>	$\leq 10\%$
<b>Protection class</b>	IP67
<b>EMV-standard</b>	according to IEC 60947-5-2
<b>Switching state</b>	LED
<b>Housing material</b>	brass, nickel-plated*
<b>Front cap</b>	PA 6.6



\* On request also with stainless steel housing and enlarged temperature range up to 120 °C.

The selection chart for these sensors is shown on the following page.

#### Dimensions

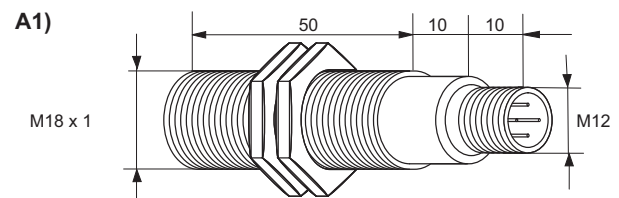
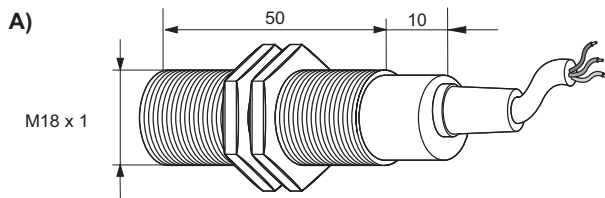

all data in mm



# MAGNETORESISTIVE SENSORS

## CYLINDER M18

### Selection chart

Article number	Designation standard Output signal (1)	Output signal pulse	Usable Switching frequency	Max. load current * = per output	Connection	Drawing (previous page)
08330000044	<b>KM2,5-M18MB-DPI</b>	<b>PNP</b>	0 - 20.000Hz	≤ 200mA	cable	A
08330000144	<b>KM2,5-M18MB-DNI</b>	<b>NPN</b>	0 - 20.000Hz	≤ 200mA	cable	A
08330000008	<b>KM2,5-M18MB-DPI-V2</b>	<b>PNP</b>	0 - 20.000Hz	≤ 200mA	connector	A1
08330000108	<b>KM2,5-M18MB-DNI-V2</b>	<b>NPN</b>	0 - 20.000Hz	≤ 200mA	connector	A1

Cable: 2m cable PVC 3 x 0,34mm<sup>2</sup>  
Connector: connector M12 4-pole

(1) f out

	Designation Phase quadrature Output signal (2)					
08330000012	<b>KM2,5-M18MB-DPI-D9</b>	<b>PNP</b>	2 - 20.000Hz	≤ 100mA*	cable	A
08330000112	<b>KM2,5-M18MB-DNI-D9</b>	<b>NPN</b>	2 - 20.000Hz	≤ 100mA*	cable	A
08330000031	<b>KM2,5-M18MB-DPI-D9-V2</b>	<b>PNP</b>	2 - 20.000Hz	≤ 100mA*	connector	A1
08330000131	<b>KM2,5-M18MB-DNI-D9-V2</b>	<b>NPN</b>	2 - 20.000Hz	≤ 100mA*	connector	A1

Cable: 2m cable PVC 4 x 0,25mm<sup>2</sup>  
Connector: connector M12 4-pole

(2) f out 1   
f out 2

	Designation Low/High flank Output signal (3)					
08330000025	<b>KM2,5-M18MB-DPI-D</b>	<b>PNP</b>	2 - 20.000Hz	≤ 100mA*	cable	A
08330000125	<b>KM2,5-M18MB-DNI-D</b>	<b>NPN</b>	2 - 20.000Hz	≤ 100mA*	cable	A
08330000026	<b>KM2,5-M18MB-DPI-D-V2</b>	<b>PNP</b>	2 - 20.000Hz	≤ 100mA*	connector	A1
08330000126	<b>KM2,5-M18MB-DNI-D-V2</b>	<b>NPN</b>	2 - 20.000Hz	≤ 100mA*	connector	A1

Cable: 2m cable PVC 4 x 0,25mm<sup>2</sup>  
Connector: connector M12 4-pole

(3) f out 1   
f out 2

Other cable lengths as requested.



## PRODUCT OVERVIEW

Product group	Designation	Article number	Matchcode	Page
Magnetoresistive	KM0,5-G10KB13-ANU-X0101	08330000048		7
Magnetoresistive	KM1,5-M12MB-DPI	08330000017		9
Magnetoresistive	KM1,5-M12MB-DNI	08330000117		9
Magnetoresistive	KM1,5-M12MB-DPI-V2	08330000045		9
Magnetoresistive	KM1,5-M12MB-DNI-V2	08330000145		9
Magnetoresistive	KM1,5-M12MB-DPI-D9	08330000011		9
Magnetoresistive	KM1,5-M12MB-DNI-D9	08330000033		9
Magnetoresistive	KM1,5-M12MB-DPI-D9-V2	08330000039		9
Magnetoresistive	KM1,5-M12MB-DNI-D9-V2	08330000139		9
Magnetoresistive	KM1,5-M12MB-DPI-D	08330000016		9
Magnetoresistive	KM1,5-M12MB-DNI-D	08330000116		9
Magnetoresistive	KM1,5-M12MB-DPI-D-V2	08330000015		9
Magnetoresistive	KM1,5-M12MB-DNI-D-V2	08330000115		9
Magnetoresistive	KM2,5-M18MB-DPI	08330000044		11
Magnetoresistive	KM2,5-M18MB-DNI	08330000144		11
Magnetoresistive	KM2,5-M18MB-DPI-V2	08330000008		11
Magnetoresistive	KM2,5-M18MB-DNI-V2	08330000108		11
Magnetoresistive	KM2,5-M18MB-DPI-D9	08330000012		11
Magnetoresistive	KM2,5-M18MB-DNI-D9	08330000112		11
Magnetoresistive	KM2,5-M18MB-DPI-D9-V2	08330000031		11
Magnetoresistive	KM2,5-M18MB-DNI-D9-V2	08330000131		11
Magnetoresistive	KM2,5-M18MB-DPI-D	08330000025		11
Magnetoresistive	KM2,5-M18MB-DNI-D	08330000125		11
Magnetoresistive	KM2,5-M18MB-DPI-D-V2	08330000026		11
Magnetoresistive	KM2,5-M18MB-DNI-D-V2	08330000126		11