

**SAFETY, CONVENIENCE, AND
MAXIMUM SYSTEM PRODUCTIVITY
FOR PROCESS AUTOMATION**

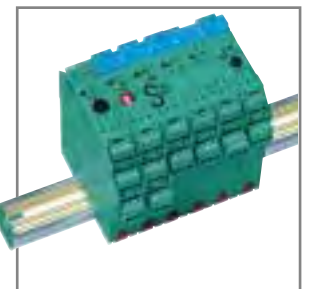



The Process Automation Department of the Pepperl+Fuchs Group is today the uncontested market leader in all three global market areas, America, Europe, and Asia, in components for intrinsically safe explosion protection.

Our target industries are the chemical, the pharmaceutical and the petrochemical industry and parts of waste water management and power systems.

In all industrial areas, Pepperl+Fuchs is a supplier and partner for end customers, control system manufacturers, system integrators, and engineering contractors.

Huge increases in networking of processes and automation systems makes it possible today for us to offer remote I/O systems and the entire fieldbus installation FieldConnex, in addition to our conventional interface components.

The newly added display and control terminals (HMI) of the EXTEC brand are our entry into diagnostics and configuration platforms for fieldbus technology.

Our level measurement, corrosion monitoring and purge & pressurization products are the field devices which round out our overall offering.

CONTENTS

4

K-SYSTEM
Interface components
on rails



14

FieldConnex®
Fieldbus installation
system
Fieldbus diagnostics



6

Hi DENSITY SYSTEM
Interface components
on the motherboard



18

**FIELDBUS
JUNCTION BOX**
Fieldbus installation
system
Fieldbus diagnostics



8

E-SYSTEM
Interface components
on 19" racks



20

**PEPPERL+FUCHS
EXTEC**



10

REMOTE I/O SYSTEMS

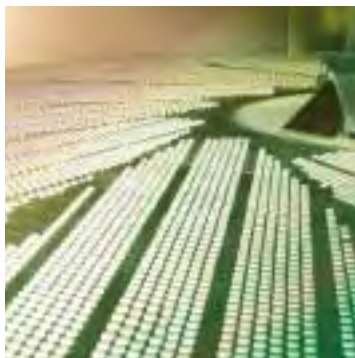

24

LEVEL CONTROL



12

HART MULTIPLEXERS



27

**CORROSION
PROTECTION
TRANSMITTER
BEBCO EPS**
Overpressure encapsulation
systems



Styrol is a colorless fluid with a sweetish smell.

It is capable of forming very long, chain-formed molecules of polystyrol.

The material polystyrol is very versatile and omnipresent in our lives.

Our K-System is just as versatile as the material polystyrol.

The K-System is part of process automation – just as styrol is part of everyday life.



THE K-SYSTEM – INTERFACE COMPONENTS FOR THE DIN-RAIL

THE K-SYSTEM IS ATTRACTIVE DUE TO ITS VERSATILITY, OFFERING YOU:

- Explosion protection through intrinsically safe signal transmission
- Galvanic isolation and decoupling between your processes and your process control
- Functional safety during processing and transmission of your signals
- Stable, reliable products to ensure a long lifetime for your installation

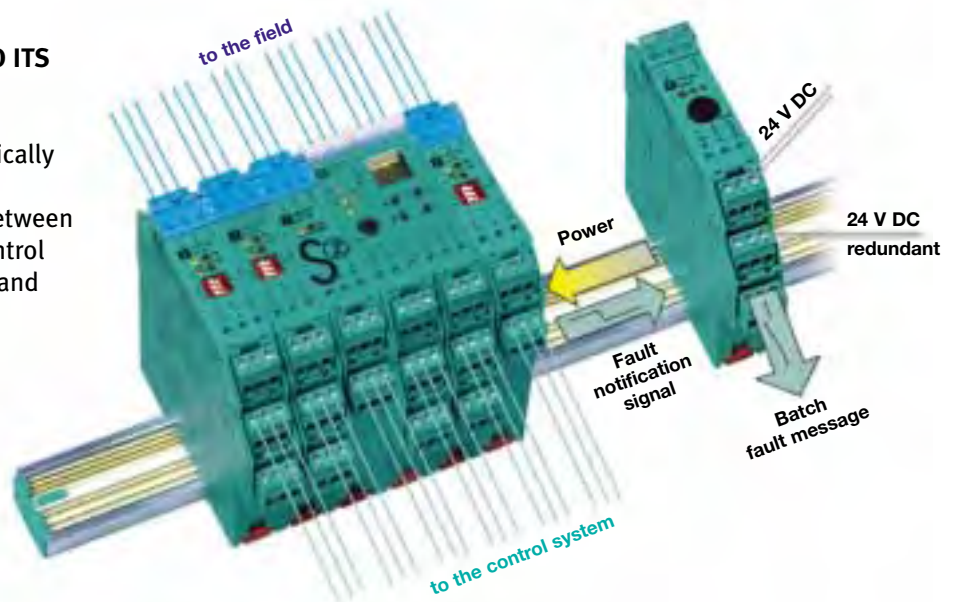

THE K-SYSTEM IS FLEXIBLE – JUST THE WAY YOU NEED IT



- C Series: Installation width 12.5 mm for optimum signal integrity



- F Series: Installation width 20 mm for optimum installation density



- F Series: Installation width 40 mm for demanding tasks

THE K-SYSTEM HAS FOR ALL BANDWIDTHS:

- High-quality galvanic isolation
- Power Rail power supply
- Redundant power supply
- Failure detection and diagnosis
- Collective error message
- HART communication to the field devices
- SIL categorization for safety system applications (IEC 61508)



- Pluggable overvoltage protection
- Suitable for Ex i circuits
- No additional wiring



Explosion protection based on international standards



Functional safety without higher price



Bidirectional HART transmission



Operation and configuration with DTM using the FDT concept and control interface PACTware™



Ethylene is a colorless and nearly odourless gas. It is highly reactive and is the basis for polyethylenes with its wide variety of product properties. Ethylene is produced by cracking (steam cracking) of benzine and is one of the most important by-products of petroleum chemistry. Steam crackers can include many thousand measurement points within explosion-hazardous areas. An ideal application for our compact, user-friendly Hi-Density system.

THE HI-DENSITY SYSTEM – INTERFACE COMPONENTS ON THE MOTHERBOARD

THE HI-DENSITY SYSTEM IS ATTRACTIVE DUE TO ITS HIGH PACKING DENSITY, OFFERING YOU:

- Explosion protection through intrinsically safe signal transmission
- Galvanic isolation and decoupling between your processes and your process control
- Functional safety during processing and transmission of your signals
- Stable, durable products to ensure a long lifetime for your installation
- Optimum signal adaptation through standard plug connectors for each control system manufacturer
- Integrated HART multiplexer functionality on the motherboard - without additional wiring



- Modules with up to four channels
- Robust screw terminals or knife terminals on the (intrinsically safe) field side
- Connector technology to the control system appropriate to your choice
- Patented on-board routing
- Collective error message for monitoring of field circuits
- Integrated HART communication to the field devices
- SIL categorization for safety system applications (IEC 61508)



Explosion protection based on international standards



Functional safety without higher price



Bidirectional HART transmission

2,2,4-trimethylpentane is the name of a fluid compound commonly called isooctane.

Isooctane is colorless, easy to ignite, and is used amongst other things as an aircraft fuel and as a paint solvent.

The scale for knocking in fuel is derived from isooctane.

Isooctane can be found in many explosion-hazardous installations in the chemical industry, particularly in refineries.

In the measurement installations of these operations, you usually find our intrinsically safe European cards, the E-System.



THE E-SYSTEM – INTERFACE COMPONENTS ON 19” RACK

THE E-SYSTEM HANDLES SAFETY AND PRODUCTIVITY IN REFINERIES AND CHEMICAL PLANTS

- Explosion protection through intrinsically safe signal transmission
- Galvanic isolation and decoupling between your processes and your process control
- Functional safety during processing and transmission of your signals
- Stable, reliable products to ensure a long lifetime for your installation



- High-packing density
- 8-channel switch amplifier
- 2-channel temperature converter
- Lead breakage and short-circuit monitoring
- Configurable via serial PC interface
- HART communication to the field devices
- SIL categorization for safety system applications (IEC 61508)



Explosion protection based on international standards



Functional safety without higher price



Bidirectional HART transmission



Operation and configuration with DTM using the FDT concept and control interface
PACTware™

Triphenylphosphine consists of colorless or yellow-white crystals, is highly soluble in organic solvents and easily forms highly soluble metal complexes. Therefore, triphenylphosphine is valuable for the synthesis of vitamins and pharmaceutical substances as well as the production of varnishes and plant protective agents. Our Remote I/O systems RPI and IS-RPI are especially suitable for the automation of the synthesis processes.



REMOTE I/O SYSTEMS – RPI AND IS-RPI

The remote I/O systems RPI and IS-RPI are modular systems for the cost-effective connection of your field signals in the explosion-hazardous and safe zones. RPI connects your conventional sensors and actuators to your process control system over the fieldbus. A variety of gateways are available for connection to different fieldbuses. Freely combinable I/O components and high modularity offers cost-saving installations. The systems are characterized by high functionality and simple handling.

RPI – REMOTE PROCESS INTERFACE FOR THE SWITCHING CABINET AND ZONE 2

- Mounting in the Ex zone, Zone 2, or in the switching cabinet
- Simple, flexible DIN rail mounting with the power rail concept
- Modular due to up to 4 channels in one module
- Overvoltage protection simply by plugging it in
- HART via PROFIBUS

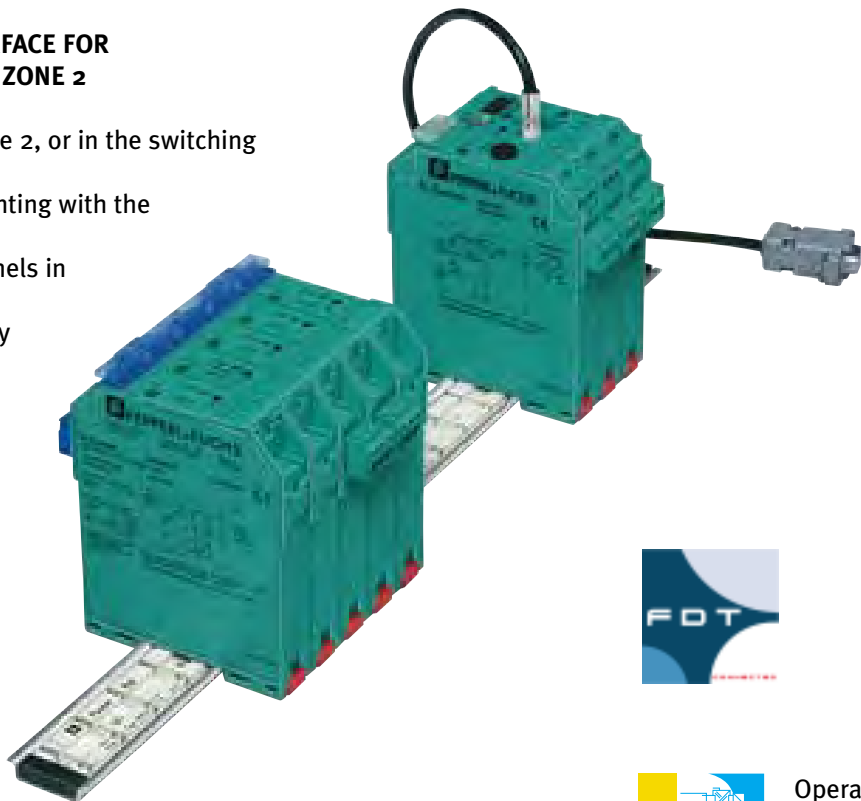

Operation and configuration with DTM using the FDT concept and control interface PACTware™

IS-RPI – REMOTE PROCESS INTERFACE FOR ZONE 1/DIVISION 1

- Mounting in the Ex zone, Zone 1/Division 1
- Ex-protected system components
- Modular, from 4 to 16 channels in a single module
- “Hot Swapping” – Devices are exchangeable while under power in the hazardous area
- HART via PROFIBUS

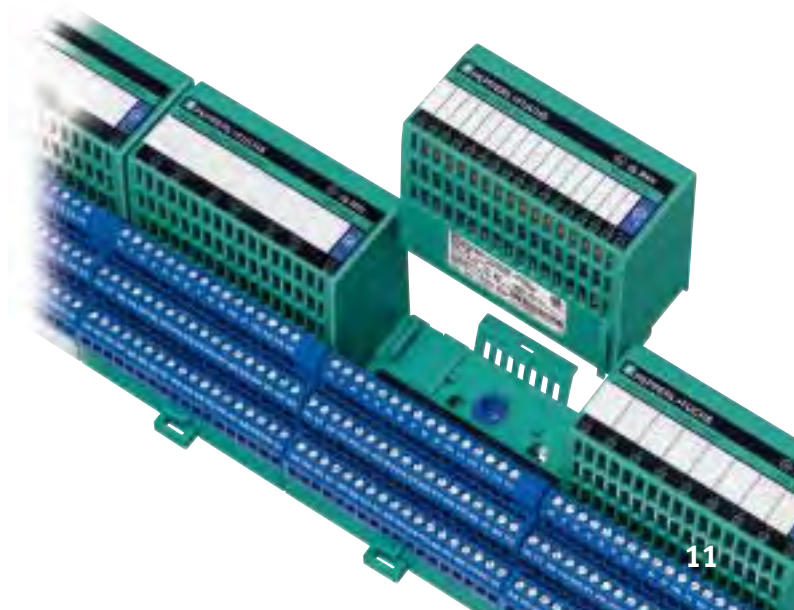



Millions of tons of plastic granulates are coloured, melted, and kneaded every year, ultimately to be injected into forms, pulled into foils, or blown into hollow parts. By combining different granulates, the properties and qualities of the products manufactured can be varied. The fine granularity of the raw materials enables combination in any mix ratio. Granularity trumps everything else. Our HART Multiplexer is part of the process control and signal processing. It is multiply granular. It is like your processes. It trumps everything.

HART MULTIPLEXERS – THE ONLINE CONNECTION TO THE FIELD DEVICE

HART multiplexers give you digital access to the configuration and diagnostic data of your HART field devices without influencing the processing of measured values. The power of HART field devices already installed can be fully utilized to increase the value of your installation. We provide customer-specific transfer interfaces for coupling to your installation control systems. HART multiplexers are ideally suited for extension, modernization, and renovation of installations in process automation.



KF-MUX

- Master/slave system for up to 7,936 field devices
- Compact design in mounted housing for 35 mm DIN rails
- Networking of up to 31 multiplexers via RS 485
- Compatible with operating and asset management software (AMS, PDM, FieldCare, PACTware)
- Assessments for loop views up to SIL3



HIS-MUX

- Stand-alone multiplexer for up to 992 field devices
- Motherboard solution
- Networking of up to 31 multiplexers via RS 485
- Compatible with operating and asset management software (AMS, PDM, FieldCare, PACTware)
- Assessments for loop views up to SIL3

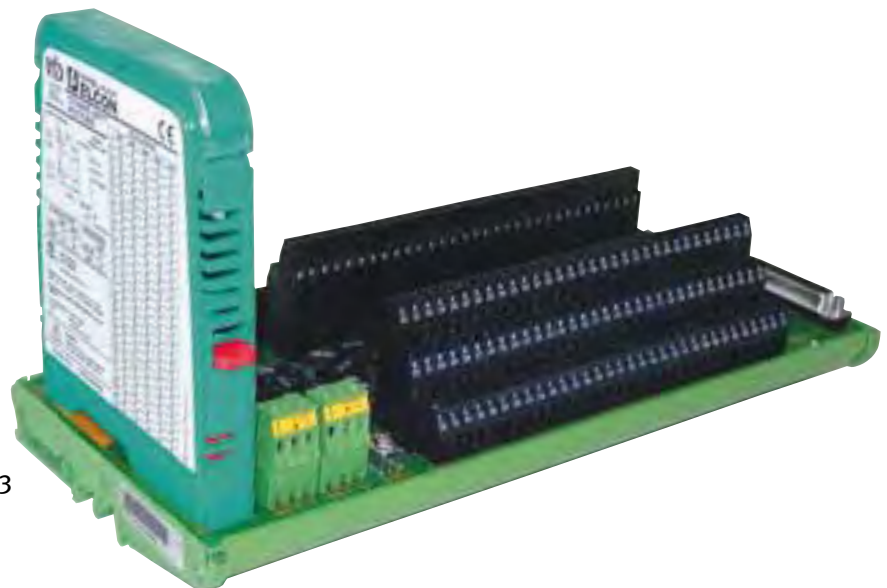

PACTware™ – MANUFACTURER- AND FIELDBUS-INDEPENDENT CONTROL INTERFACE

Using PACTware™, you can configure and parameterize devices and systems in your installation with a single control interface. The unified FDT (Field Device Tool) interface enables the best possible control concepts for the unification of your installation documentation. There are numerous functions available for online monitoring.

- Fieldbus-independent operation of devices and systems
- Fast, efficient integration of devices with arbitrary interfaces
- Investment security due to shared use and continued development at PACTware™ e. V. member companies



Colors influence our lives. We use color to express ourselves and represent ourselves.

The ruby, most noble of stones, is the sign of power. Ruby red is considered the color of vigour and passion. And it's with passion that we continue to develop the FieldConnex[®] system for you: components and solutions to transmit data from the control system into the Ex-zone via fieldbus.

Ruby red: a plant for color production, too, relies on FieldConnex[®].





FieldConnex® – COMPLETE TECHNOLOGY FOR THE FIELDBUS

POWER HUB POWER SUPPLY

Our reliable power supply and installation technology for IEC 61158-2 bus systems. The High-Power-Trunk enables connection of the highest number of field devices, even in explosive areas.

- Integration into any control system
- Options with redundancy
- Very low dissipation power
- Selectable with or without galvanic isolation
- For maximum lifetime and availability
- Transparent coupling of PROFIBUS DP and PA

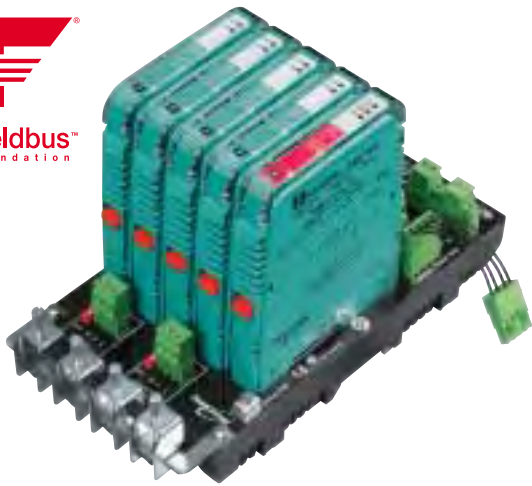
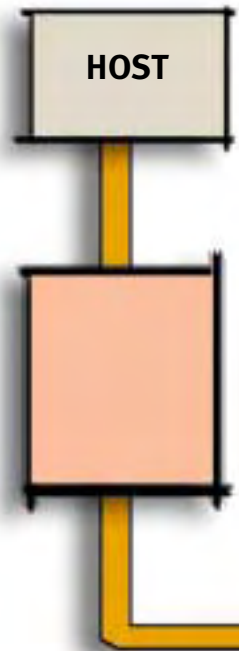

Power Hubs can be equipped with online fieldbus diagnostics.

K-SYSTEM POWER SUPPLIES

- Robust technology from a market leader
- Power Rail simplifies installation
- Extremely compact and energy-efficient
- Test plugs are easy to attach

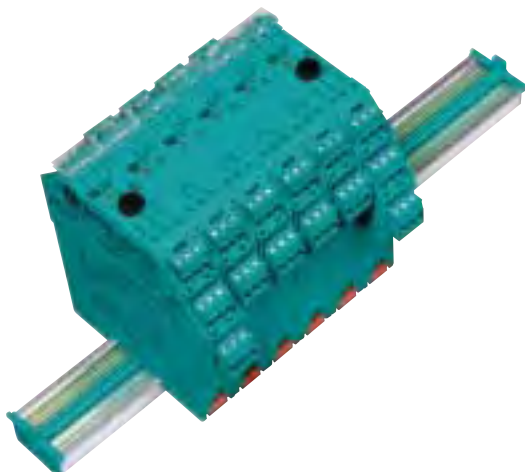

ACTIVE FIELDBUS INSTALLATION SYSTEM FOR THE EX ZONE

FieldConnex installation technology has the right connection for you to realize the optimal concept for your system. Spur lines are connected to the trunk through Segment Protectors and FieldBarriers. This enables efficient connection of the highest number of field devices even in explosive areas - with your choice of protection concept: FISCO, FNICO, or Entity.

FIELDBARRIER

- Installation in Zone 1/Class I, Div 2
- High-Power Trunk with intrinsic safety in connection
- Galvanic isolation



SEGMENT PROTECTOR

- Installation in Zone 2/Class I, Div 2
- Work in running operation
- Spur line with short-circuit protection



FIELDBUS PROCESS INTERFACES

Your analogue and binary signals are optimally connected to the fieldbus. FieldConnex integrates your signals with added value, like monitoring of end positions and stroke-time of valves. Temperature sensors can be connected using two-, three-, or four-wire systems. Your sensors and actuators can naturally also be mounted in Zone 0.

- Valve couplers
- Binary input signals (PROFIBUS only)
- Temperature Multiplex Input (FOUNDATION Fieldbus only)



ADVANCED DIAGNOSTICS FOR YOUR FIELDBUS

Commissioning, monitoring, and error correction require tools and instruments for the display of signal strength and quality. The Advanced Diagnostic Module for the Power Hub monitors the fieldbus physics and communication online and in real time. Measured values can easily be evaluated on the PC. Using trend and alarm functions, the system warns of any possible interruption in communications, thus increasing system availability.

A variety of measurement options support you in error correction. This brings the system back up faster. Fieldbus systems have never been so easy to manage. Advanced Diagnostics are for any user with requirements like high system availability and efficient commissioning and error correction.



T

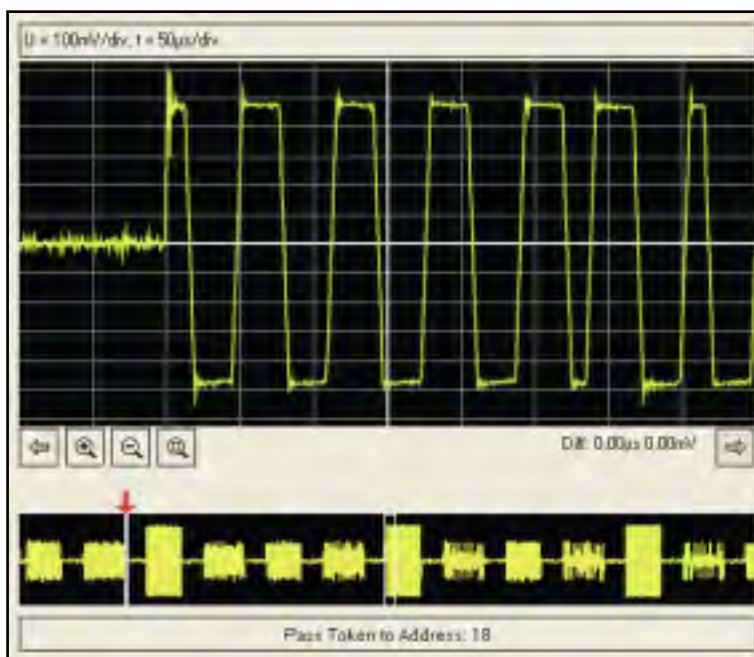

The built-in oscilloscope shows the exact characteristic curve, helping to analyze fieldbus communications.

Wherever gas and oil are transported, distributed, and processed, the most stringent requirements exist for system availability and safety for people and systems. These are exactly the points addressed and solved by our robust Field Junction Box.



FIELDBUS DISTRIBUTOR – YOUR PARTNER FOR CUSTOM SOLUTIONS

No application is like any other, and every application always places new requirements on the features and configuration of a fieldbus distributor. This fact is addressed by our new modular Field Junction Box system for our familiar FieldConnex products. You can not only customize the housing size, but everything from the screw connectors of the electronics to the overvoltage protection can be selected to customize your Field Junction Box to your particular needs. Besides a custom-fit solution for your application, the Field Junction Box allows the fastest installation possible on site, reducing engineering costs at the same time.



- Ex-certified installation solutions for the fieldbus in Zones 1/2/21/22 and Div. 1/Div. 2
- Customer-oriented availability
- Customer- and industry-specific solutions for fieldbus distributors (non-Ex solutions as well)

HOUSING FEATURES

- SS316L/1.4404 high-gloss polish
- Condensation runoff/ventilation
- M10 grounding bolts
- Mounting bracket
- Door hinges
- DIN rail
- Different box sizes:
 - 280 mm x 170 mm x 100 mm
 - 300 mm x 200 mm x 120 mm
 - 377 mm x 377 mm x 160 mm
 - 480 mm x 400 mm x 160 mm

Field Junction Box also available
in polyester (GRP) housing

Powerful catalysts are decisive for production processes in the chemical industry, for both business and ecological reasons. Powerful HMI systems (Human Machine Interface) from Pepperl+Fuchs EXTEC allow optimum control, operation, and monitoring of production processes in the chemical, pharmaceutical, oil and gas industries.



PEPPERL+FUCHS EXTEC – HMI OPERATION AND MONITORING IN THE HAZARDOUS AREA

The strengths of Pepperl+Fuchs EXTEC are in the areas of development, production, and marketing of explosion-protected electronic device systems and components, like intrinsically safe electronic display and control device systems, Ex PC systems, Exi weighing and dosing terminals, Exi data collection systems, and so on, all for the most difficult of requirements.



TERMEX – INTRINSICALLY SAFE CONTROL TERMINALS FOR USE IN CHEMISTRY, PHARMA, AND PETROCHEMISTRY

- Text and graphics terminals, non-Ex versions available
- Extended temperature range -20 °C ... +60 °C
- Digital inputs/outputs
- Control panel mounting, wall, or cabinet housing
- Backlight display
- PLC and computer interfaces
(MPI, Profibus, 3964R/RK512, AS511,
Modbus/RTU, DF1, etc.)
- Certified for use in EN 45501-compliant operations
requiring calibration
- Freely plannable using TERMEXpro and EPCA
- Wide variety of terminal peripherals in the Ex zone
- Approvals: ATEX categories II 2G and II 3D, etc.

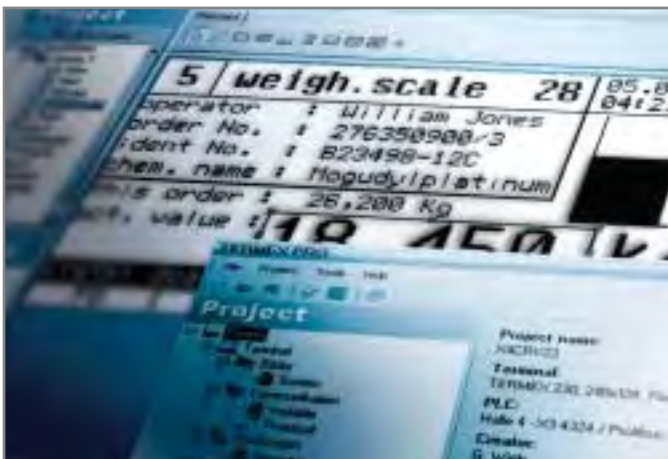

TERMEXpro – THE PROJECT PLANNING SOFTWARE FOR GRAPHICAL PLANNING OF ALL CONTROL AND DISPLAY DEVICES IN THE TERMEX FAMILY

- Standardized data types per DIN 61131-3
- Language configuration (32 languages)
- Online help with “Natural Search” function
- Automatic project documentation
- PLC simulator

PCEX/VISUEX – THE FIRST ON THE MARKET! THE ORIGINAL!

Flexible visualization solutions require standard PC platforms. The PCEX410/412 devices of the VISUEX product family correspond exactly to these requirements and are thus ideally suited for the use of customer-specified software packages.

- 10", 12" display, touchscreen
- Powerful processor with 256/512 MB RAM and 20 GB hard drive
- IS peripheral interfaces for barcode reader systems, keyboard, USB, etc.
- Exe interfaces: Ethernet, RS485/TTY, USB
- Integrated software package for data backup and recovery, etc.
- Approvals: ATEX categories II 2G and II 2D, etc.





**IPC-EX –
THE PC CONTROL STATION FOR THE MOST CHALLENGING OPERATING
AND VISUALIZATION TASKS OF PROCESSES IN CHEMISTRY, PHARMACY,
PETROCHEMISTRY**

The modularity of the individual components “Display – keyboard – housing – mounting variant” allows customer-specific solutions based on well-tested standard components.

- Compatibility with all PC operating systems
- 15”, 18”, and 21” LCD monitors, display, touchscreen
- Transmission distances of up to 1km
- Mounting variants (wall, carrier arm, stand)
- Intrinsically safe peripheral interfaces for barcode reader systems, etc.
- Approvals: ATEX categories II 2G and II 3D, etc.

AND MORE ...

- SCANEX** – Intrinsically safe barcode reader
- Cable/radio scanner
 - Stationary miniscanner
 - Categories II 2G and II 3D

- TASTEX** – Intrinsically safe PC keyboards for the Ex zone
- Trackball, touchpad
 - Category II 2G

- COMPEX** – Intrinsically safe components and systems for scale systems





Large parts of the Earth are covered with water, but the supply of the world's population with clean drinking water is one of our greatest challenges. With a comprehensive line of products for continuous level measurements and for limit value detection, we can solve your particular measurement tasks in a variety of media and application areas. We can meet your challenges.

LEVEL CONTROL – MORE THAN EXACT VALUES...

VIBRACON MINI – VERSATILE APPLICABILITY

- Well-tested tuning fork measurement principle
- Minimal size for narrow installation
- Installation possible in pipelines to 40 mm
- Function control on site via switch state display
- Service-friendly plug connectors and variants for DC, AC, or AS-Interface



VIBRACON NAMUR – WELL-TESTED AND COMPACT

- Well-tested tuning fork measurement principle
- Compact construction and extended-length versions
- All current process connections and coatings
- National and international approvals (Exia, Exd, WHG, FM, CSA, EMEDG ...)



VIBRACON S LVL-B – VIBRATION LIMIT SWITCH FOR GRANULAR MATERIALS

Vibracon S is a robust level limit switch for containers with fine- or coarse grained, non-fluidized materials from a density of 200 g/l on up. Different designs enable versatile use, even in areas with dust explosion hazard.

- No calibration; simple commissioning
- No jams of coarse-grained material
- No mechanical parts
- Process temperature up to 150°C
- Approval compliant with ATEX II 1/3 D



FILL LEVEL SYSTEMS – CONTINUOUS MEASUREMENT



PULSCON – MODERN MICROWAVE SYSTEMS

A constant voltage transmission pulse is directed along a single conductor, the sensor rod, and reflected at the material surface. From the propagation time of the pulse, the evaluation circuitry can determine the level of the material.

- For fluids and granular materials
- Measurement range up to 35 m
- Rod, rope, and coax versions
- Simple commissioning and calibration
- Independent from media properties
- As independent as possible of process influences like pressure, temperature, and moving surfaces
- Optional display
- Modular process connections
- Different electrical interfaces: 2/4-wire, AC/DC, 4 mA - 20 mA; HART, PROFIBUS PA, FOUNDATION Fieldbus
- Use in Ex Zone 0/Division 1
- Approvals: ATEX, FM CSA

LUC-M SERIES – COMPACT, INTELLIGENT, COST-EFFECTIVE

- System for level measurement in solids or fluids
- Application areas: Storage tanks, Lagertanks, agitator containers, dumps, and conveyor belts
- Measurement regardless of density, conductivity and relative dielectric constant of the material
- Optional linearisation of the measured value across 32 supporting points
- Network-independent supply via batteries or solar cells possible
- System integration for HART, PROFIBUS PA and FOUNDATION Fieldbus available
- LUC-M is approved for operation in hazardous areas according to ATEX, FM and CSA
- Protection class IP68/Type 6 allows flooding of the measuring instrument





**CORRTRAN™ CORROSION PROTECTION TRANSMITTER
FOR ONLINE MONITORING**

CorrTran™ monitors general and localized corrosion in real time using a 4 - 20 mA signal. The corrosion rate or pitting factor are available as a standard 2-wire, 4 - 20mA process value. The probe is simple to integrate into existing systems.

- Online corrosion monitoring in real time
- General or localized corrosion monitoring (pitting)
- Process pressure up to 100 bar
- Customer-specific configuration
- ATEX/US approval in accordance with II 1 G EEX ia II C T4/Division 1



**BEBCO EPS –
THE INTERNATIONAL-COMPLIANT
PURGE & PRESSURIZATION SYSTEM**

Purge & pressurization protection is suitable for many applications and is one of the most flexible Ex protection solutions. This ignition protection class makes it possible to operate non-Ex-capable devices in hazardous areas of Zone 1/Division 1 and Zone 2/Division 2. The idea behind this technology is to prevent penetration of a potentially explosive atmosphere into a closed protective housing using a standing overpressure technique. With the 3000 and 4000 component series, Pepperl+Fuchs Bebcos EPS offers a solution for the control and automation of devices, machines, robots, and systems in Zones/Divisions 1 and 2.





Pepperl+Fuchs organizes training on the topics of explosion protection, intrinsic safety, and functional safety (SIL). Since the training dates are continually updated, we recommend that you visit our process automation home page.

www.pepperl-fuchs.com/pa/training

Worldwide Headquarters

Pepperl+Fuchs GmbH
68307 Mannheim · Germany
Tel. 0621 776-0
Email: info@de.pepperl-fuchs.com

USA Headquarters

Pepperl+Fuchs Inc.
Twinsburg, Ohio 44087 · USA
Tel. +1 330 4253555
Email: sales@us.pepperl-fuchs.com

Asia Pacific Headquarters

Pepperl+Fuchs Pte Ltd.
Singapore 139942
Company Registration No. 199003130E
Tel. +65 67799091
Email: sales@sg.pepperl-fuchs.com

www.pepperl-fuchs.com