

OIL-X EVOLUTION

WS Water Separators
High Efficiency Bulk Liquid Removal



OIL-X EVOLUTION WS water separators have been designed for the efficient removal of bulk liquid contamination from compressed air.

Compressed air purification equipment must deliver uncompromising performance and reliability whilst providing the right balance of air quality with the lowest cost of operation. Many manufacturers offer products for the filtration and purification of contaminated compressed air, which are often selected only upon their initial purchase cost, with little or no regard for the air quality they provide, the cost of operation throughout their life or indeed their environmental impact. When purchasing purification equipment, delivered air quality, the overall cost of ownership and the equipment's environmental impact must always be considered.



The Parker domnick hunter Design Philosophy

Parker domnick hunter has been supplying industry with high efficiency filtration and purification products since 1963. Our philosophy 'Designed for Air Quality & Energy Efficiency' ensures products that not only provide the user with clean, high quality compressed air, but also with low lifetime costs and reduced CO₂ emissions.



Contact Information:

Parker Hannifin Ltd
domnick hunter Industrial division
Dukesway, Team Valley Trading Estate
Gateshead, Tyne and Wear
England NE11 0PZ

Tel: +44 (0)191 402 9000
Fax: +44 (0)191 482 6296
Email: dhindsales@parker.com
www.domnickhunter.com

Benefits:

- Protects coalescing filters from bulk liquid contamination.
- Helps provide air quality in accordance with ISO 8573-1:2001 the international standard for compressed air quality
- High liquid removal efficiencies at all flow conditions
- Suitable for all compressed air applications
- Suitable for all compressor types, including variable flow
- The world's most energy efficient compressed air water separators
- Low pressure losses for low operational costs
- Low lifetime costs
- All OIL-X EVOLUTION water separators are covered by a 10 year housing guarantee.
- Helps reduce the release of CO₂ into the environment



ENGINEERING YOUR SUCCESS.

Separation Efficiency (models 010 - 7200F)

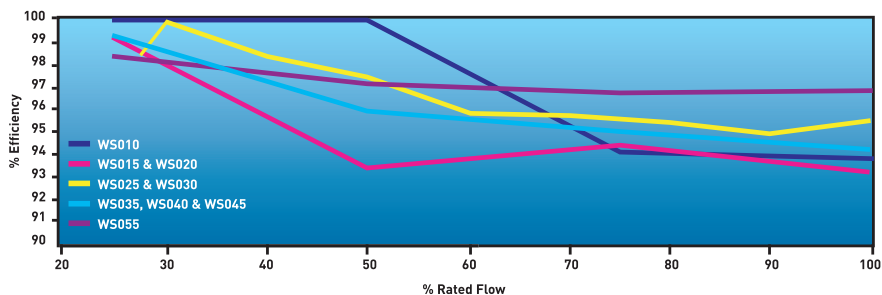

Differential Pressure versus Flow (models 010 - 055)

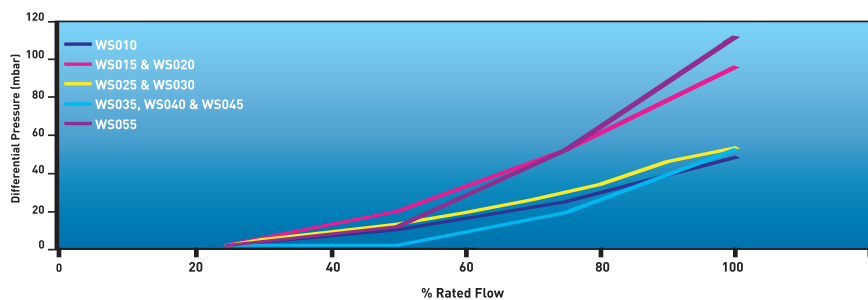

Product Selection

Stated flows are for operation at 7 bar g (100 psi g) with reference to 20°C, 1 bar a, 0% relative water vapour pressure.

	Model	Pipe Size	L/S	m ³ /min	m ³ /hr	cfm
Cast Aluminum Range	WS010A <input type="checkbox"/> FX	1/4"	10	0.6	36	21
	WS010B <input type="checkbox"/> FX	3/8"	10	0.6	36	21
	WS010C <input type="checkbox"/> FX	1/2"	10	0.6	36	21
	WS015B <input type="checkbox"/> FX	3/8"	40	2.4	144	85
	WS020C <input type="checkbox"/> FX	1/2"	40	2.4	144	85
	WS020D <input type="checkbox"/> FX	3/4"	40	2.4	144	85
	WS020E <input type="checkbox"/> FX	1"	40	2.4	144	85
	WS025D <input type="checkbox"/> FX	3/4"	110	6.6	396	233
	WS030E <input type="checkbox"/> FX	1"	110	6.6	396	233
	WS030F <input type="checkbox"/> FX	1 1/4"	110	6.6	396	233
	WS030G <input type="checkbox"/> FX	1 1/2"	110	6.6	396	233
	WS035F <input type="checkbox"/> FX	1 1/4"	350	21	1260	742
	WS040G <input type="checkbox"/> FX	1 1/2"	350	21	1260	742
	WS045H <input type="checkbox"/> FX	2"	350	21	1260	742
	WS055I <input type="checkbox"/> FX	2 1/2"	800	48	2880	1695
	WS055J <input type="checkbox"/> FX	3"	800	48	2880	1695
	WS1000	G 4	1000	60	3600	2119
Carbon Steel Range	WS250F	DN40	350	21	1260	742
	WS800F	DN80	800	48	2880	1695
	WS1000F	DN100	1000	60	3600	2119
	WS1800F	DN150	1800	108	6480	3814
	WS3000F	DN200	3000	180	10800	6357
	WS4800F	DN250	4800	288	17280	10171
	WS7200F	DN300	7200	421	25920	14885

Note: Connection sizes, (010 - 055) BSPT/NPT option available, G = BSPP and DN = flanged connection.

To correctly select a water separator model, the flow rate of the water separator must be adjusted for the minimum operating pressure of the system.

1. Obtain the minimum operating pressure and maximum compressed air flow rate at the inlet of the filter.
2. Select the correction factor for minimum operating pressure from the CFP table (always round down e.g. for 5.3 bar, use 5 bar correction factor)
3. Calculate the minimum filtration capacity
Minimum Filtration Capacity = Compressed Air Flow Rate x CFP
4. Using the minimum filtration capacity, select a water separator model from the flow rate tables above (water separator selected must have a flow rate equal to or greater than the minimum filtration capacity)

Correction Factors

Line Pressure		Correction Factor pressure (CFP)
bar g	psi g	
1	15	4.00
1.5	22	3.20
2	29	2.67
2.5	37	2.29
3	44	2.00
3.5	51	1.78
4	58	1.60
4.5	66	1.45
5	73	1.33
5.5	80	1.23
6	87	1.14
6.5	95	1.07
7	100	1.00
7.5	110	0.97
8	116	0.94
8.5	124	0.91
9	131	0.88
9.5	139	0.86
10	145	0.84
10.5	153	0.82
11	160	0.80
11.5	168	0.78
12	174	0.76
12.5	183	0.75
13	189	0.73
13.5	197	0.72
14	203	0.71
14.5	212	0.69
15	218	0.68
15.5	226	0.67
16	232	0.66
16.5	241	0.65
17	248	0.64
17.5	256	0.63
18	263	0.62
18.5	270	0.62
19	277	0.61
19.5	285	0.60
20	292	0.59

Technical Data

Grade	Water Separator Models	Min Operating Pressure		Max Operating Pressure		Min Operating Temp		Max Operating Temp	
		bar g	psi g	bar g	psi g	°C	°F	°C	°F
WS	010A □ FX - 055J □ FX	1	15	16	232	2	35	80	176
WS	1000	1	15	16	232	2	35	66	150
WS	250F - 7200F	1	15	16	232	2	35	66	150

Weights and Dimensions

Model	Pipe Size	Height (H)		Width (W)		Depth (D)		Weight	
		mm	ins	mm	ins	mm	ins	kg	lbs
WS010A □ FX	1/4"	181	7.2	76	3.0	64	2.5	0.6	1.3
WS010B □ FX	3/8"	181	7.2	76	3.0	64	2.5	0.6	1.3
WS010C □ FX	1/2"	181	7.2	76	3.0	64	2.5	0.6	1.3
WS015B □ FX	3/8"	235	9.3	97	3.8	84	3.3	1.1	2.4
WS020C □ FX	1/2"	235	9.3	97	3.8	84	3.3	1.1	2.4
WS020D □ FX	3/4"	235	9.3	97	3.8	84	3.3	1.1	2.4
WS020E □ FX	1"	235	9.3	97	3.8	84	3.3	1.1	2.4
WS025D □ FX	3/4"	275	10.8	129	5.1	115	4.5	2.2	4.8
WS030E □ FX	1"	364	14.3	129	5.1	115	4.5	2.7	5.9
WS030F □ FX	1 1/4"	364	14.3	129	5.1	115	4.5	2.7	5.9
WS030G □ FX	1 1/2"	364	14.3	129	5.1	115	4.5	2.7	5.9
WS035F □ FX	1 1/4"	432	17	170	6.7	156	6.1	5.1	11.2
WS040G □ FX	1 1/2"	524	20.6	170	6.7	156	6.1	5.7	12.5
WS045H □ FX	2"	524	20.6	170	6.7	156	6.1	5.7	12.5
WS055I □ FX	2 1/2"	832	32.8	205	8.1	181	7.1	13.9	30.6
WS055J □ FX	3"	832	32.8	205	8.1	181	7.1	13.9	30.6
WS1000	G 4	1071	42.2	420	16.5	282	11.1	41	90
WS250F	DN40	595	23.4	304	12.0	220	8.7	31	68
WS800F	DN80	1070	42.1	370	14.6	285	11.2	66	146
WS1000F	DN100	1120	44.1	450	17.7	340	13.4	102	225
WS1800F	DN150	1240	48.8	580	22.8	460	18.1	191	434
WS3000F	DN200	1585	62.4	750	29.5	640	25.2	397	875
WS4800F	DN250	1570	61.8	862	33.9	715	28.2	537	1184
WS7200F	DN300	1610	63.4	1000	39.4	840	33.1	675	1488

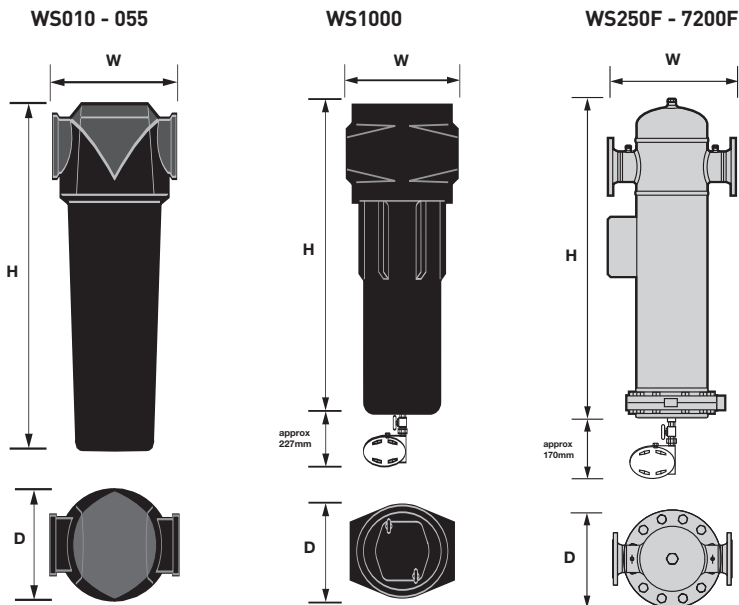

Water Separator Coding Example

WS010 - WS055

GRADE	MODEL	PIPE SIZE	CONNECTION TYPE	DRAIN OPTION	INCIDENT MONITOR OPTION
WS	3 digit code shown above	Letter denotes pipe size	B = BSPT N = NPT	F = Float M = Manual	X = None
WS	010	A	B	F	X

} Example code

Optional Accessories



Filter Fixing Kits

Fixing clamp allows quick and simple connection of multiple filter housings.



Filter Mounting Brackets

Mounting brackets provide additional support to filters installed in flexible piping systems or OEM equipment.

Filter Model		
005 - 010		FXKE1
015 - 020		FXKE2
025 - 030		FXKE3
035 - 045		FXKE4
050 - 055		FXKE5

Filter Model		
005 - 010		MBKE1
015 - 020		MBKE2
025 - 030		MBKE3
035 - 045		MBKE4
050 - 055		MBKE5

Other Filtration Products

- Compressed air filters
- Oil vapour removal filters
- Filters with working pressures to 50 bar g
- Filters with working pressures to 350 bar g
- Alternative compressed air filter elements
- Oil / water separators
- Sterile air filtration
- Stainless steel filters
- Vacuum pump protection filters
- Vacuum pump exhaust filters
- Medical vacuum filters