

ST 3000 Smart Transmitter Series 900 Absolute Pressure Models Specifications

34-ST-03-66 August 2011



Introduction

In 1983, Honeywell introduced the first Smart Pressure Transmitter—the ST 3000®. In 1989, Honeywell launched the first all digital, bi-directional protocol for smart field devices. Today, its ST 3000 Series 900 Pressure Transmitters continue to bring proven “smart” technology to a wide spectrum of pressure measurement applications.

Honeywell absolute pressure transmitters STA92L, STA94L, STA97L and STA922, STA940 are used in applications in which high accuracy in the vacuum range of pressure is needed. Typical applications include low-pressure measurement in vacuum distillation columns, where energy savings are directly proportional to the vacuum in the column. Honeywell STA92L/STA94L and STA922/STA940 transmitters can be used in a wide spectrum of hazardous environments in perfect safety to provide proven, repeatable pressure measurements.



Figure 1 –
On the left is an In-line Models STA92L, STA94L and STA97L and on the right is Model STA922, STA940. All Series 900 Absolute Pressure Transmitters feature proven piezoresistive sensor technology

Models		
STA922	0 to 780 mmHgA	0 to 1,040 mbarA
STA92L	0 to 780 mmHgA	0 to 1,040 mbarA
STA940	0 to 500 psia	0 to 35 barA
STA94L	0 to 500 psia	0 to 35 barA
STA97L	0 to 3,000 psia	0 to 206.8 barA

All ST 3000 transmitters can be ordered to provide one of the following output communication options.

Communications options
4-20 mA
Honeywell Digitally Enhanced (DE)
HART® (versions 5.x or 6.x)
FOUNDATION™ Fieldbus

When digitally integrated with Honeywell’s Process Knowledge System™, EXPERION PKS™. ST 3000 instruments provide a more accurate process variable as well as advanced diagnostics. Honeywell’s cost-effective ST 3000 S900 transmitters lead the industry in:

- Stability
- Reliability

ST 3000 S900 Transmitter Benefits
Stability = ±0.01% per year
Reliability = 470 years MTBF

The devices provide comprehensive self-diagnostics to help users maintain high uptime, meet regulatory requirements, and attain high quality standards. S900 transmitters allow smart performance at analog prices. Accurate, reliable and stable, Series 900 transmitters offer greater turndown ratio than conventional transmitters.

Description

The ST 3000 transmitter can replace any 4 to 20 mA output transmitter in use today and operates over a standard two-wire system.

The measuring means is a piezoresistive sensor, which actually contains three sensors in one. It contains a differential pressure sensor, a temperature sensor, and a static pressure sensor.

Microprocessor-based electronics provide higher span-turndown ratio, improved temperature and pressure compensation, and improved accuracy.

The transmitter's meter body and electronics housing resist shock, vibration, corrosion, and moisture. The electronics housing contains a compartment for the single-board electronics, which is isolated from an integral junction box. The single-board electronics is replaceable and interchangeable with any other ST 3000 Series 100 or Series 900 model transmitters.

Like other Honeywell transmitters, the ST 3000 features two-way communication and configuration capability between the operator and the transmitter through several Honeywell field-rated portable configuration devices, including the Smart Field Communicator (SFC) and the Multiple Communication Configurator (MC ToolKit). While both are made for in-field use, the MC Toolkit also can be ordered for use in intrinsically safe environments.

The SCT 3000 Smartline® Configuration Toolkit provides an easy way to configure instruments using a personal computer. The toolkit enables configuration of devices before shipping or installation. The SCT 3000 can operate in the offline mode to configure an unlimited number of devices. The database can then be loaded down-line during commissioning.

Features

- Choice of linear or square root output conformity is a simple configuration selection.
- Direct digital integration with Experion PKS and other control systems provides local measurement accuracy to the system level without adding typical A/D and D/A converter inaccuracies.
- Unique piezoresistive sensor automatically compensates input for temperature and static pressure. Added "smart" features include configuring lower and upper range values, simulating accurate analog output, and selecting preprogrammed engineering units for display.
- Smart transmitter capabilities with local or remote interfacing means significant manpower efficiency improvements in commissioning, start-up, and ongoing maintenance functions.
- ST 3000 transmitters feature full Dual-Seal certification based on ANSI/NFPA 70-202 and ANSI/ISA 12.27.01 requirements without the use of additional seal protection elements.
- ST 3000 transmitters are available fully compliant to SIL 2/3 requirements as a standard option.

Advanced Diagnostics

ST 3000 is now available for both HART® 6 and Foundation™ Fieldbus with advanced diagnostics that minimize unplanned plant outages, minimize maintenance costs and by providing the industry's most reliable transmitter.

- Provide advanced warning of possible failure events and avoid costly shutdowns.
- Three levels of failure reporting
- Comprehensive list of on-board diagnostics (Ref. ST 3000 User manual with HART® 6, 34-ST-25-17 Rev: June 09 and Foundation™ Fieldbus option manual 34-ST-25-15 Rev: June 09)

Operating Conditions – All Models

Parameter	Reference Condition		Rated Condition		Operative Limits		Transportation and Storage	
	°C	°F	°C	°F	°C	°F	°C	°F
Ambient Temperature	25±1	77±2	-25 to 70	-13 to 158	-40 to 85	-40 to 185	-55 to 125	-67 to 257
Meter Body Temperature								
STA922/STA92L	25±1	77±2	See Figure 2		See Figure 2		-55 to 125	-67 to 257
STA940/STA94L	25±1	77±2	-25 to 70	-13 to 158	-40 to 80	-40 to 176	-55 to 125	-67 to 257
STA97L	25±1	77±2	-25 to 70	-13 to 158	-40 to 80	-40 to 176	-55 to 125	-67 to 257
Humidity %RH	10 to 55		0 to 100		0 to 100		0 to 100	
Vacuum Region, Minimum Pressure	STA922/STA92L See Figure 2. STA940/STA94L Operate within specifications above 25 mmHgA (33 mbarA). Short term exposure (2 hours at 70°C/158°F) to full vacuum will not result in damage. STA97L							
Supply Voltage, Current, and Load Resistance	Voltage Range: 10.8 to 42.4 Vdc at terminals Current Range: 3.0 to 21.8 mA Load Resistance: 0 to 1,440 ohms (as shown in Figure 3)							
Maximum Allowable Working Pressure (MAWP)⁴ (ST 3000 products are rated to Maximum Allowable Working Pressure. MAWP depends on Approval Agency and transmitter materials of construction.)	STA922/STA92L = 780 mmHgA, 1,040 mbarA STA940/STA94L = 500 psia, 34.47 barA STA97L = 3,000 psia, 206.8 barA Units can withstand overpressure of 1.5X MAWP without damage.							

⁴ Consult factory for MAWP of ST 3000 transmitters with CSA approval.

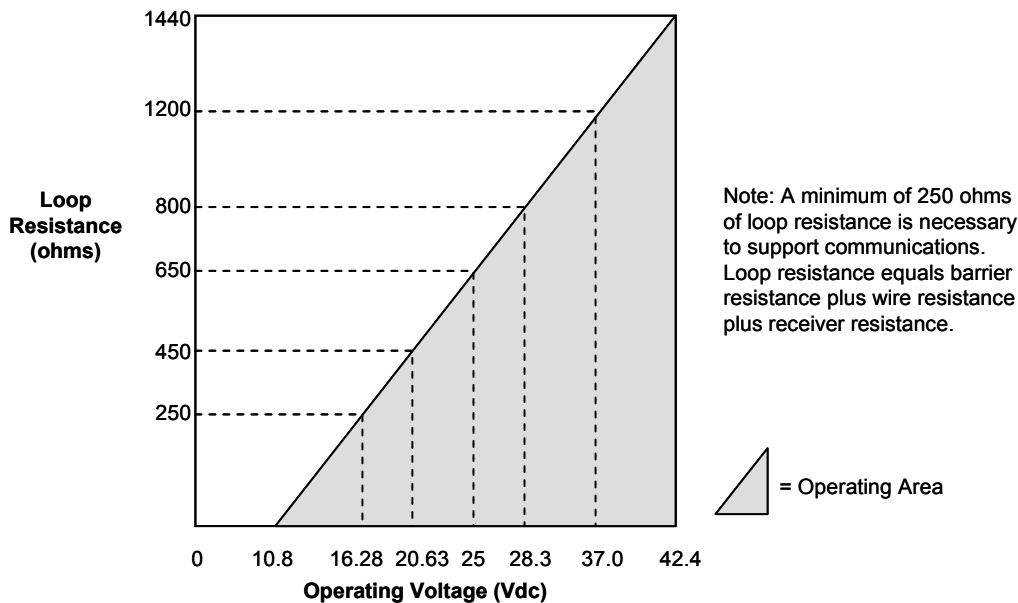

Figure 3 — Supply voltage and loop resistance chart

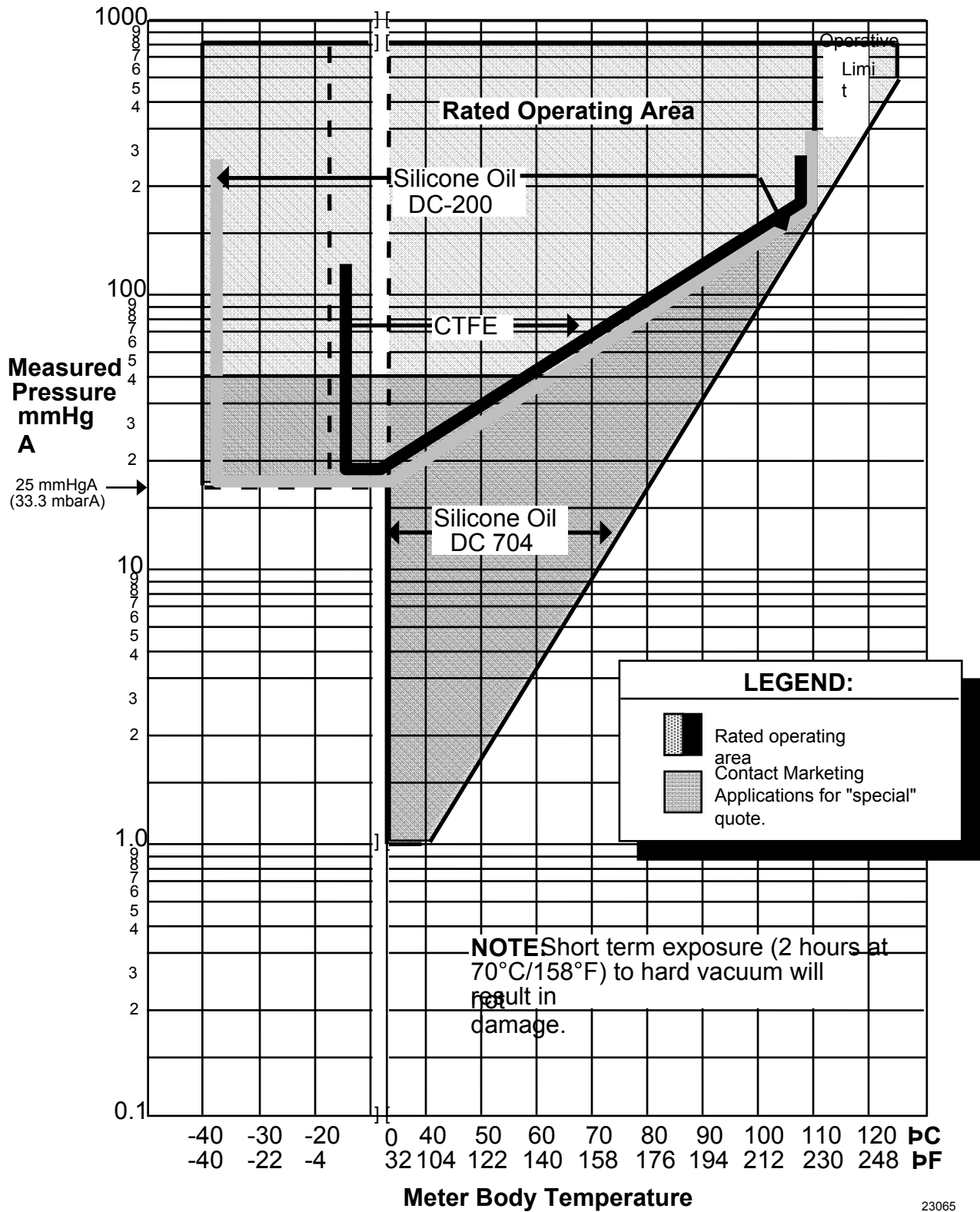

Figure 2 — Measured pressure versus meter body temperature chart for model STA922/STA92L

Performance under Rated Conditions* - Model STA922 (0 to 780 mmHgA/1,040 mbarA)

Parameter	Description
Upper Range Limit mmHgA mbarA	780 (39.2°F/4°C is standard reference temperature for inH ₂ O range.) 1,040
Minimum Span mmHgA mbarA	50 67
Turndown Ratio	15 to 1
Zero Suppression	No limit except minimum span within 0 (zero) to +100% URL.
Accuracy (Reference – Includes combined effects of linearity, hysteresis, and repeatability) <ul style="list-style-type: none"> • Accuracy includes residual error after averaging successive readings. • For FOUNDATION™ Fieldbus use Digital Mode specifications. • For HART® use Analog Mode specifications. 	In Analog Mode: ±0.10% of calibrated span or upper range value (URV), whichever is greater, terminal based. For URV below reference point (90 mmHgA), accuracy equals: $\pm \left[0.05 + 0.05 \left(\frac{90 \text{ mmHgA}}{\text{span mmHgA}} \right) \right] \text{ or } \pm \left[0.05 + 0.05 \left(\frac{120 \text{ mbarA}}{\text{span mbarA}} \right) \right] \text{ in \% of span}$ In Digital Mode: ±0.075% of calibrated span or upper range value (URV), whichever is greater, terminal based. For URV below reference point (90 mmHgA), accuracy equals: $\pm \left[0.025 + 0.05 \left(\frac{90 \text{ mmHgA}}{\text{span mmHgA}} \right) \right] \text{ or } \pm \left[0.025 + 0.05 \left(\frac{120 \text{ mbarA}}{\text{span mbarA}} \right) \right] \text{ in \% of span}$
Zero Temperature Effect per 28°C (50°F)	In Analog Mode: ±0.1625% of span. For URV below reference point (300 mmHgA), effect equals: $\pm \left[0.0125 + 0.15 \left(\frac{300 \text{ mmHgA}}{\text{span mmHgA}} \right) \right] \text{ or } \pm \left[0.0125 + 0.15 \left(\frac{400 \text{ mbarA}}{\text{span mbarA}} \right) \right] \text{ in \% of span}$ In Digital Mode: ±0.15% of span. For URV below reference point (300 mmHgA), effect equals: $\pm 0.10 \left(\frac{300 \text{ mmHgA}}{\text{span mmHgA}} \right) \text{ or } \pm 0.10 \left(\frac{400 \text{ mbarA}}{\text{span mbarA}} \right) \text{ in \% of span}$
Combined Zero and Span Temperature Effect per 28°C (50°F)	In Analog Mode: ±0.25% of span. For URV below reference point (300 mmHgA), effect equals: $\pm \left[0.10 + 0.15 \left(\frac{300 \text{ mmHgA}}{\text{span mmHgA}} \right) \right] \text{ or } \pm \left[0.10 + 0.15 \left(\frac{400 \text{ mbarA}}{\text{span mbarA}} \right) \right] \text{ in \% of span}$ In Digital Mode: ±0.225% of span. For URV below reference point (300 mmHgA), effect equals: $\pm \left[0.075 + 0.15 \left(\frac{300 \text{ mmHgA}}{\text{span mmHgA}} \right) \right] \text{ or } \pm \left[0.75 + 0.15 \left(\frac{400 \text{ mbarA}}{\text{span mbarA}} \right) \right] \text{ in \% of span}$

* Performance specifications are based on reference conditions of 25°C (77°F), 10 to 55% RH, and 316L Stainless Steel barrier diaphragm.

Performance under Rated Conditions* - Model STA92L (0 to 780 mmHgA/1,040 mbarA)

Parameter	Description
Upper Range Limit mmHgA mbarA	780 (0°C/32°F is standard reference temperature for mmHg range.) 1,040
Minimum Span mmHgA mbarA	50 67
Turndown Ratio	15 to 1
Zero Suppression	No limit except minimum span within 0 (zero) to +100% URL.
Accuracy (Reference – Includes combined effects of linearity, hysteresis, and repeatability) <ul style="list-style-type: none"> • Accuracy includes residual error after averaging successive readings. • For FOUNDATION™ Fieldbus use Digital Mode specifications. • For HART® use Analog Mode specifications. 	<p>In Analog Mode: ±0.10% of calibrated span or upper range value (URV), whichever is greater, terminal based. For URV below reference point (90 mmHgA), accuracy equals:</p> $\pm \left[0.05 + 0.05 \left(\frac{90 \text{ mmHgA}}{\text{span mmHgA}} \right) \right] \text{ or } \pm \left[0.05 + 0.05 \left(\frac{120 \text{ mbarA}}{\text{span mbarA}} \right) \right] \text{ in \% of span}$ <p>In Digital Mode: ±0.075% of calibrated span or upper range value (URV), whichever is greater, terminal based. For URV below reference point (90 mmHgA), accuracy equals:</p> $\pm \left[0.025 + 0.05 \left(\frac{90 \text{ mmHgA}}{\text{span mmHgA}} \right) \right] \text{ or } \pm \left[0.025 + 0.05 \left(\frac{120 \text{ mbarA}}{\text{span mbarA}} \right) \right] \text{ in \% of span}$
Zero Temperature Effect per 28°C (50°F)	<p>In Analog Mode: ±0.2125% of span. For URV below reference point (300 mmHgA), effect equals:</p> $\pm \left[0.0125 + 0.20 \left(\frac{300 \text{ mmHgA}}{\text{span mmHgA}} \right) \right] \text{ or } \pm \left[0.0125 + 0.20 \left(\frac{400 \text{ mbarA}}{\text{span mbarA}} \right) \right] \text{ in \% of span}$ <p>In Digital Mode: ±0.20% of span. For URV below reference point (300 mmHgA), effect equals:</p> $\pm 0.20 \left(\frac{300 \text{ mmHgA}}{\text{span mmHgA}} \right) \text{ or } \pm 0.20 \left(\frac{400 \text{ mbarA}}{\text{span mbarA}} \right) \text{ in \% of span}$
Combined Zero and Span Temperature Effect per 28°C (50°F)	<p>In Analog Mode: ±0.30% of span. For URV below reference point (300 mmHgA), effect equals:</p> $\pm \left[0.10 + 0.20 \left(\frac{300 \text{ mmHgA}}{\text{span mmHgA}} \right) \right] \text{ or } \pm \left[0.10 + 0.20 \left(\frac{400 \text{ mbarA}}{\text{span mbarA}} \right) \right] \text{ in \% of span}$ <p>In Digital Mode: ±0.275% of span. For URV below reference point (300 mmHgA), effect equals:</p> $\pm \left[0.075 + 0.20 \left(\frac{300 \text{ mmHgA}}{\text{span mmHgA}} \right) \right] \text{ or } \pm \left[0.075 + 0.20 \left(\frac{400 \text{ mbarA}}{\text{span mbarA}} \right) \right] \text{ in \% of span}$

* Performance specifications are based on reference conditions of 25°C (77°F), 10 to 55% RH, and 316L Stainless Steel barrier diaphragm.

Performance under Rated Conditions* - Models STA940/STA94L (0 to 500 psia/35 barA)

Parameter	Description
Upper Range Limit	500 35
Minimum Span	5 0.35
Turndown Ratio	100 to 1
Zero Suppression	No limit except minimum span within 0 (zero) to +100% URL.
Accuracy (Reference – Includes combined effects of linearity, hysteresis, and repeatability) <ul style="list-style-type: none"> Accuracy includes residual error after averaging successive readings. For FOUNDATION™ Fieldbus use Digital Mode specifications. For HART® use Analog Mode specifications. 	In Analog Mode: ±0.10% of calibrated span or upper range value (URV), whichever is greater, terminal based. For URV below reference point (20 psia), accuracy equals: $\pm \left[0.05 + 0.05 \left(\frac{20 \text{ psia}}{\text{span psia}} \right) \right] \text{ or } \pm \left[0.05 + 0.05 \left(\frac{1.4 \text{ barA}}{\text{span barA}} \right) \right] \text{ in \% of span}$ In Digital Mode: ±0.075% of calibrated span or upper range value (URV), whichever is greater, terminal based. For URV below reference point (20 psia), accuracy equals: $\pm \left[0.025 + 0.05 \left(\frac{20 \text{ psia}}{\text{span psia}} \right) \right] \text{ or } \pm \left[0.025 + 0.05 \left(\frac{1.4 \text{ barA}}{\text{span barA}} \right) \right] \text{ in \% of span}$
Zero Temperature Effect per 28°C (50°F)	In Analog Mode: ±0.1625% of span. For URV below reference point (50 psia), effect equals: $\pm \left[0.0125 + 0.15 \left(\frac{50 \text{ psia}}{\text{span psia}} \right) \right] \text{ or } \pm \left[0.0125 + 0.15 \left(\frac{3.5 \text{ barA}}{\text{span barA}} \right) \right] \text{ in \% of span}$ In Digital Mode: ±0.15% of span. For URV below reference point (50 psia), effect equals: $\pm 0.15 \left(\frac{50 \text{ psia}}{\text{span psia}} \right) \text{ or } \pm 0.15 \left(\frac{3.5 \text{ barA}}{\text{span barA}} \right) \text{ in \% of span}$
Combined Zero and Span Temperature Effect per 28°C (50°F)	In Analog Mode: ±0.25% of span. For URV below reference point (50 psia), effect equals: $\pm \left[0.10 + 0.15 \left(\frac{50 \text{ psia}}{\text{span psia}} \right) \right] \text{ or } \pm \left[0.10 + 0.15 \left(\frac{3.5 \text{ barA}}{\text{span barA}} \right) \right] \text{ in \% of span}$ In Digital Mode: ±0.225% of span. For URV below reference point (50 psia), effect equals: $\pm \left[0.075 + 0.15 \left(\frac{50 \text{ psia}}{\text{span psia}} \right) \right] \text{ or } \pm \left[0.075 + 0.15 \left(\frac{3.5 \text{ barA}}{\text{span barA}} \right) \right] \text{ in \% of span}$

* Performance specifications are based on reference conditions of 25°C (77°F), 10 to 55% RH, and 316L Stainless Steel barrier diaphragm.

Performance under Rated Conditions* - Models STA97L (0 to 3,000 psia/35 barA)

Parameter	Description
Upper Range Limit psia barA	3,000 206.8
Minimum Span psia mbarA	30 2.07
Turndown Ratio	100 to 1
Zero Suppression	No limit except minimum span within 0 (zero) to +100% URL.
Accuracy (Reference – Includes combined effects of linearity, hysteresis, and repeatability) <ul style="list-style-type: none"> • Accuracy includes residual error after averaging successive readings. • For FOUNDATION™ Fieldbus use Digital Mode specifications. • For HART® use Analog Mode specifications. 	In Analog Mode: ±0.075% of calibrated span or upper range value (URV), whichever is greater, terminal based. For URV calibrated below reference point (750 psia), accuracy equals: $\pm \left[0.025 + 0.05 \left(\frac{750 \text{ psia}}{\text{span psia}} \right) \right] \text{ or } \pm \left[0.025 + 0.05 \left(\frac{51.7 \text{ barA}}{\text{span barA}} \right) \right] \text{ in \% of span}$ In Digital Mode: ±0.0625% of calibrated span or upper range value (URV), whichever is greater, terminal based. For URV calibrated below reference point (750 psia), accuracy equals: $\pm \left[0.0125 + 0.05 \left(\frac{750 \text{ psia}}{\text{span psia}} \right) \right] \text{ or } \pm \left[0.0125 + 0.05 \left(\frac{51.7 \text{ barA}}{\text{span barA}} \right) \right] \text{ in \% of span}$
Zero Temperature Effect per 28°C (50°F)	In Analog Mode: ±0.1125% of calibrated span. For URV below reference point (500 psia), effect equals: $\pm \left[0.0125 + 0.10 \left(\frac{500 \text{ psia}}{\text{span psia}} \right) \right] \text{ or } \pm \left[0.0125 + 0.10 \left(\frac{34.47 \text{ barA}}{\text{span barA}} \right) \right] \text{ in \% of span}$ In Digital Mode: ±0.05% of calibrated span. For URV below reference point (500 psia), effect equals: $\pm 0.10 \left(\frac{500 \text{ psia}}{\text{span psia}} \right) \text{ or } \pm 0.10 \left(\frac{34.47 \text{ barA}}{\text{span barA}} \right) \text{ in \% of span}$
Combined Zero and Span Temperature Effect per 28°C (50°F)	In Analog Mode: ±0.175% of calibrated span. For URV below reference point (500 psia), effect equals: $\pm \left[0.075 + 0.10 \left(\frac{500 \text{ psia}}{\text{span psia}} \right) \right] \text{ or } \pm \left[0.075 + 0.10 \left(\frac{34.47 \text{ barA}}{\text{span barA}} \right) \right] \text{ in \% of span}$ In Digital Mode: ±0.075% of calibrated span. For URV below reference point (500 psia), effect equals: $\pm \left[0.05 + 0.10 \left(\frac{500 \text{ psia}}{\text{span psia}} \right) \right] \text{ or } \pm \left[0.05 + 0.10 \left(\frac{34.47 \text{ barA}}{\text{span barA}} \right) \right] \text{ in \% of span}$

* Performance specifications are based on reference conditions of 25°C (77°F), 10 to 55% RH, and 316L Stainless Steel barrier diaphragm.

Performance under Rated Conditions – All Models

Parameter	Description
Output (two-wire)	Analog 4 to 20 mA or DE digital communications mode. Options available for FOUNDATION™ Fieldbus and HART® protocol.
Supply Voltage Effect	0.005% span per volt.
Damping Time Constant	Adjustable from 0 to 32 seconds digital damping.
NAMUR NE 43 Compliance (Option “NE”)	Transmitter failure information is generated when the measuring information is invalid or no longer present. Failure information is transmitted as a current signal but outside the normal 4-20 mA measurement signal level. Transmitter failure values are: ≤ 3.6 mA and ≥ 21.0 mA. The normal signal range is ≥ 3.8 mA and ≤ 20.5 mA.
SIL 2/3 Compliance	SIL certified to IEC 61508 for non-redundant use in SIL 2 related Safety Systems (single use) and for redundant (multiple) use in SIL 3 Safety Systems through TÜV Nord Sys Tec GmbH & Co. KG under the following standards: IEC61508-1: 1998; IEC 61508-2: 2000; IEC61508-3: 1998.
Lightning Protection Option (Code “LP”)	Leakage Current: 10 microamps max. @ 42.4 VDC, 93°C Impulse Rating: 10/20 μ sec. 5,000 Amps (50 strikes) 10,000 Amps (20 strikes) (rise/decay) 10/1,000 μ sec. 250 Amps (1,000 strikes) 500 Amps (400 strikes)

Physical and Approval Bodies

Parameter	Description
Barrier Diaphragms Material	316L SS, Hastelloy® C-276 ²
Process Head Material	STA922/STA940: 316 SS ⁴ , Carbon Steel (zinc-plated) ⁵ , Hastelloy® C-276 ⁶ STA92L/STA94L/STA97L: 316 SS ⁴
Head Gaskets	STA922/STA940: Viton® is standard. Graphite is also optional.
Meter Body Bolting	STA922/STA940: Carbon Steel (zinc-plated, standard) ⁵ or A286 SS (NACE) bolts and 302/304 SS (NACE) nuts for heads.
Mounting Bracket	Carbon Steel (zinc-plated) or Stainless Steel angle bracket or Carbon Steel flat bracket available.
Vent/Drain Valves & Plugs ¹	316 SS ⁴ , Hastelloy® C-276 ² , Monel® 400 ⁸ (Models STA922 and STA940 only)
Fill Fluid	Silicone DC® 200 oil or CTFE (Chlorotrifluoroethylene) Note that DC® 704 is available – Please contact Product Marketing.
Electronic Housing	Epoxy-Polyester hybrid paint. Low Copper-Aluminum. Meets NEMA 4X (watertight) and NEMA 7 (explosion proof). Stainless steel optional.
Process Connections	STA922/STA940: 1/2-inch F-NPT, DIN STA92L/STA94L/STA97L: 1/2-inch F-NPT, 1/2 inch M-NPT, 9/16 AMINCO, DIN 19213
Wiring	Accepts up to 16 AWG (1.5 mm diameter).
Mounting	Can be mounted in virtually any position using the standard mounting bracket. Bracket is designed to mount on 2-inch (50 mm) vertical or horizontal pipe. See Figures 4 and 4a .
Dimensions	See Figures 5 and 5a .
Net Weight	STA922/STA940: 7.0 pounds (3.2 Kg) STA92L/STA94L: 3.8 pounds (1.7 kg)

¹ Vent/Drains are sealed with Teflon® or PTFE

² Hastelloy® C-276 or UNS N10276

⁴ Supplied as 316 SS or as Grade CF8M, the casting equivalent of 316 SS.

⁵ Carbon Steel heads are zinc-plated and not recommended for water service due to hydrogen migration. For that service, use 316 stainless steel wetted Process Heads.

⁶ Hastelloy® C-276 or UNS N10276. Supplied as indicated or as Grade CW12MW, the casting equivalent of Hastelloy® C-276

Note: Pressure transmitters that are part of safety equipment for the protection of piping (systems) or vessel(s) from exceeding allowable pressure limits, (equipment with safety functions in accordance with Pressure Equipment Directive 97/23/EC article 1, 2.1.3), require separate examination

Certifications

	Type of Protection	Comm. Option	Field Parameters	Temp. Codes
FM ApprovalsSM	Explosionproof: Class I, Division 1, Groups A, B, C, D locations Dust Ignition Proof: Class II, III, Division 1, Groups E, F, G locations, Enclosure Type 4X	All	All	T5 Ta = 93°C
	Intrinsically Safe: Class I, II, III, Division 1, Groups A, B, C, D, E, F, G locations, Enclosure Type 4X	4-20 mA / DE	Vmax = 42.4V Imax = 225mA Ci = 4.2nF Li = * Pi = 1.2W	T4 Ta = 93°C
		4-20 mA /	Vmax = 30V Imax = 225mA Ci = 4.2nF Li = * Pi = 1.2W	T4 Ta = 93°C
	Intrinsically Safe: Class I, II, III, Division 1, Groups A, B, C, D, E, F, G locations; Class 1, Zone 0, AEx ia Group IIC, Enclosure Type 4X / IP 66/67	Fieldbus – Entity (Not FISCO)	Vmax = 32V Imax = 120mA Ci = 4.2nF Li = 0 Pi = 0.84W	T4 Ta = 40°C T3 Ta = 93°C
		Fieldbus – Entity (Not FISCO)	Vmax = 24V Imax = 250mA Ci = 4.2nF Li = 0 Pi = 1.2W	T4 Ta = 40°C T3 Ta = 93°C
		FISCO	Vmax = 17.5V Imax = 380mA Ci = 4.2nF Li = 0 Pi = 5.32W	T4 Ta = 40°C T3 Ta = 93°C
	Nonincendive: Class I, Division 2, Groups A, B, C, D locations, Enclosure Type 4X	4-20 mA / DE	Vmax = 42.4V Imax = 225mA Ci = 4.2nF Li = * Pi = 1.2W	T4 Ta = 93°C
		4-20 mA / HART	Vmax = 30V Imax = 225mA Ci = 4.2nF Li = * Pi = 1.2W	T4 Ta = 93°C
	Nonincendive: Class I, Division 2, Groups A, B, C, D; Suitable for: Class II, Division 2, Groups F&G; Class III, Division 2; Class I, Zone 2, Group IIC, Enclosure Type 4X / IP 66/67	Fieldbus – Entity (Not FNICO)	Vmax = 32V Imax = 120mA Ci = 4.2nF Li = 0 Pi = 0.84W	T4 Ta = 40°C T3 Ta = 93°C
		Fieldbus – Entity (Not FNICO)	Vmax = 24V Imax = 250mA Ci = 4.2nF Li = 0 Pi = 1.2W	T4 Ta = 40°C T3 Ta = 93°C
		FNICO	Vmax = 32V Ci = 4.2nF Li = 0	T4 Ta = 40°C T3 Ta = 93°C

* Li = 0 except Li = 150µH when Option ME, Analog Meter, is selected.

FM ApprovalsSM is a service mark of FM Global

	Type of Protection	Comm. Option	Field Parameters	Temp. Codes	
Canadian Standards Association (CSA)	Explosion Proof: Class I, Division 1, Groups B, C, D locations Dust Ignition Proof: Class II, III, Division 1, Groups E, F, G locations, Enclosure Type 4X	All	All	T4 Ta = 93°C	
	Intrinsically Safe: Class I, II, III, Division 1, Groups A, B, C, D, E, F, G locations, Enclosure Type 4X	4-20 mA / DE	Vmax = 42V Imax = 225mA Ci = 4.2nF Li = * Pi = 1.2W	T4 Ta = 93°C	
		4-20 mA / HART	Vmax = 42V Imax = 225mA Ci = 4.2nF Li = * Pi = 1.2W	T4 Ta = 93°C	
		Fieldbus – Entity (Not FISCO)	Vmax = 24V Imax = 250mA Ci = 4.2nF Li = 0 Pi = 1.2W	T4 Ta = 40°C T3 Ta = 93°C	
	Nonincendive: Class I, Division 2, Groups A, B, C, D locations, Enclosure Type 4X	4-20 mA / DE	Vmax = 42.4V Imax = 225mA Ci = 4.2nF Li = * Pi = 1.2W	T4 Ta = 93°C	
		4-20 mA / HART	Vmax = 30V Imax = 225mA Ci = 4.2nF Li = * Pi = 1.2W	T4 Ta = 93°C	
		Fieldbus – Entity (Not FNICO)	Vmax = 24V Imax = 250mA Ci = 4.2nF Li = 0 Pi = 1.2W	T4 Ta = 40°C T3 Ta = 93°C	
	Canadian Registration Number (CRN):	All ST 3000 models except STG19L, STG99L, STG170 and STG180 have been registered in all provinces and territories in Canada and are marked CRN: 0F8914.5C.			

	Type of Protection	Comm. Option	Field Parameters	Temp. Codes
IECEX International Electrotechnical Commission (LCIE)	Flameproof, Zone 1: Ex d IIC, Enclosure IP 66/67	All	All	T5 Ta = -50 to 93°C T6 Ta = -50 to 78°C
	Intrinsically Safe, Zone 0/1: Ex ia IIC, Enclosure IP 66/67	4-20 mA / DE	Ui = 30V Ii = 100mA Ci = 4.2nF Li = * Pi = 1.2W	T4 Ta = -50 to 93°C T5 Ta = -50 to 85°C T6 Ta = -50 to 70°C
		4-20 mA / HART	Ui = 30V Ii = 100mA Ci = 4.2nF Li = * Pi = 1.2W	T4 Ta = -50 to 93°C T5 Ta = -50 to 63°C T6 Ta = -50 to 48°C
		Fieldbus (Not FISCO)	Ui = 24V Ii = 250mA Ci = 4.2nF Li = 0 Pi = 1.2W	T3 Ta = -50 to 93°C T4 Ta = -50 to 40°C

* Li = 0 except Li = 150µH when Option ME, Analog Meter, is selected.

	Type of Protection	Comm. Option	Field Parameters	Temp. Codes
SAEx (South Africa)	Flameproof, Zone 1: Ex d IIC, Enclosure IP 66/67	All	All	T5 Ta = -50 to 93°C T6 Ta = -50 to 78°C
	Intrinsically Safe, Zone 0/1: Ex ia IIC, Enclosure IP 66/67	4-20 mA / DE	Ui = 30V Ii = 100mA Ci = 4.2nF Li = * Pi = 1.2W	T4 Ta = -50 to 93°C T5 Ta = -50 to 85°C T6 Ta = -50 to 70°C
		4-20 mA / HART	Ui = 30V Ii = 100mA Ci = 4.2nF Li = * Pi = 1.2W	T4 Ta = -50 to 93°C T5 Ta = -50 to 63°C T6 Ta = -50 to 48°C
		Fieldbus (Not FISCO)	Ui = 24V Ii = 250mA Ci = 4.2nF Li = 0 Pi = 1.2W	T3 Ta = -50 to 93°C T4 Ta = -50 to 40°C
	Multiple Marking: Flameproof, Zone 1: Ex d IIC, Enclosure IP 66/67 Intrinsically Safe, Zone 0/1: Ex ia IIC, Enclosure IP 66/67 NOTE: The user must determine the type of protection required for installation of the equipment. The user shall then check the box [√] adjacent to the type of protection used on the equipment certification nameplate. Once a type of protection has been checked on the nameplate, subsequently the equipment shall not be reinstalled using any of the other certification types.	4-20 mA / DE	Ui = 30V Ii = 100mA Ci = 4.2nF Li = * Pi = 1.2W	T4 Ta = -50 to 93°C T5 Ta = -50 to 85°C T6 Ta = -50 to 70°C
		4-20 mA / HART	Ui = 30V Ii = 100mA Ci = 4.2nF Li = * Pi = 1.2W	T4 Ta = -50 to 93°C T5 Ta = -50 to 63°C T6 Ta = -50 to 48°C
		Fieldbus (Not FISCO)	Ui = 24V Ii = 250mA Ci = 4.2nF Li = 0 Pi = 1.2W	T3 Ta = -50 to 93°C T4 Ta = -50 to 40°C

Li = 0 except Li = 150µH when Option ME, Analog Meter, is selected

	Type of Protection	Comm. Option	Field Parameters	Temp. Codes
ATEX (LCIE)	Flameproof, Zone 0: ⊕ II 1 D, Ex tD Enclosure IP 66/67	All	All	A20 IP6X T95°C Ta = 93°C or T80°C Ta = 78°C
	Flameproof, Zone 1: ⊕ II 2 GD, Ex d IIC, Ex tD Enclosure IP 66/67	All	All	T5 Ta = -50 to +93°C T6 Ta = -50 to +78°C, A21 IP6X T95°C Ta = 93°C or T80°C Ta = 78°C
	Intrinsically Safe, Zone 0/1: ⊕ II 1 G, Ex ia IIC, Enclosure IP 66/67	4-20 mA / DE	Ui = 30V Ii = 100mA Ci = 4.2nF Li = * Pi = 1.2W	T4 Ta = -50 to 93°C T5 Ta = -50 to 85°C T6 Ta = -50 to 70°C
		4-20 mA / HART	Ui = 30V Ii = 100mA Ci = 4.2nF Li = * Pi = 1.2W	T4 Ta = -50 to 93°C T5 Ta = -50 to 63°C T6 Ta = -50 to 48°C
		Fieldbus (Not FISCO)	Ui = 24V Ii = 250mA Ci = 4.2nF Li = 0 Pi = 1.2W	T3 Ta = -50 to 93°C T4 Ta = -50 to 40°C
	Non-Sparking, Zone 2: ⊕ II 3 G, Ex nA IIC (Honeywell), Enclosure IP 66/67	4-20 mA / DE	Ui = 30V Ii = 100mA Ci = 4.2nF Li = * Pi = 1.2W	T4 Ta = -50 to 93°C T5 Ta = -50 to 85°C T6 Ta = -50 to 70°C
		4-20 mA / HART	Ui = 30V Ii = 100mA Ci = 4.2nF Li = * Pi = 1.2W	T4 Ta = -50 to 93°C T5 Ta = -50 to 63°C T6 Ta = -50 to 48°C
		Fieldbus (Not FNICO)	Ui = 24V Ii = 250mA Ci = 4.2nF Li = 0 Pi = 1.2W	T3 Ta = -50 to 93°C T4 Ta = -50 to 40°C
	Multiple Marking: Flameproof, Zone 1: ⊕ II 2 G, Ex d IIC Intrinsically Safe, Zone 0/1: ⊕ II 1 G, Ex ia IIC Non-Sparking, Zone 2: ⊕ II 3 G, Ex nA IIC NOTE: The user must determine the type of protection required for installation of the equipment. The user shall then check the box [√] adjacent to the type of protection used on the equipment certification nameplate. Once a type of protection has been checked on the nameplate, subsequently the equipment shall not be reinstalled using any of the other certification types.	4-20 mA / DE	Ui = 30V Ii = 100mA Ci = 4.2nF Li = * Pi = 1.2W	T4 Ta = -50 to 93°C T5 Ta = -50 to 85°C T6 Ta = -50 to 70°C
		4-20 mA / HART	Ui = 30V Ii = 100mA Ci = 4.2nF Li = * Pi = 1.2W	T4 Ta = -50 to 93°C T5 Ta = -50 to 63°C T6 Ta = -50 to 48°C
		Fieldbus (Not FISCO/FNICO)	Ui = 24V Ii = 250mA Ci = 4.2nF Li = 0 Pi = 1.2W	T3 Ta = -50 to 93°C T4 Ta = -50 to 40°C

* Li = 0 except Li = 150µH when Option ME, Analog Meter, is selected.

	Type of Protection	Comm. Option	Field Parameters	Temp. Codes
INMETRO (CERTUSP) Brazil	Flameproof, Zone 1: BR-Ex d IIC Enclosure IP 66/67	All	All	T5 Ta = -50 to 93°C T6 Ta = -50 to 78°C
	Intrinsically Safe, Zone 0/1: BR-Ex ia IIC Enclosure IP 66/67	4-20 mA / DE	Ui = 30V Ii = 100mA Ci = 4.2nF Li = * Pi = 1.2W	T4 Ta = -50 to 93°C T5 Ta = -50 to 85°C T6 Ta = -50 to 70°C
		4-20 mA / HART	Ui = 30V Ii = 100mA Ci = 4.2nF Li = * Pi = 1.2W	T4 Ta = -50 to 93°C T5 Ta = -50 to 63°C T6 Ta = -50 to 48°C
		Fieldbus (Not FISCO)	Ui = 24V Ii = 250mA Ci = 4.2nF Li = 0 Pi = 1.2W	T3 Ta = -50 to 93°C T4 Ta = -50 to 40°C

Li = 0 except Li = 150µH when Option ME, Analog Meter, is selected.

ST 3000 Pressure Transmitter Marine Certificate (MT Option)	This certificate defines the certifications covered for the ST 3000 Pressure Transmitter family of products, including the SMV 3000 Smart Multivariable Transmitter. It represents the compilation of the five certificates Honeywell currently has covering the certification of these products into marine applications. For ST 3000 Smart Pressure Transmitter and SMV 3000 Smart Multivariable Transmitter
	American Bureau of Shipping (ABS) - 2009 Steel Vessel Rules 1-1-4/3.7, 4-6-2/5.15, 4-8-3/13 & 13.5, 4-8-4/27.5.1, 4-9-7/13. Certificate number: 04-HS417416-PDA
	Bureau Veritas (BV) - Product Code: 389:1H. Certificate number: 12660/B0 BV
	Det Norske Veritas (DNV) - Location Classes: Temperature D, Humidity B, Vibration A, EMC B, Enclosure C. For salt spray exposure; enclosure of 316 SST or 2-part epoxy protection with 316 SST bolts to be applied. Certificate number: A-11476
	Korean Register of Shipping (KR) - Certificate number: LOX17743-AE001
	Lloyd's Register (LR) - Certificate number: 02/60001(E1) & (E2)

<p>European Pressure Equipment Directive (PED) (97/23/EC)</p>	<p>The ST 3000 Smart Pressure Transmitters are in conformity with the essential requirements of the Pressure Equipment Directive.</p> <p>Honeywell ST 3000 Smart Pressure Transmitters are designed and manufactured in accordance with the applicable portions of Annex I, Essential Safety Requirements, and sound engineering practices. These transmitters have no pressurized internal volume, or have a pressurized internal volume rated less than 200 bar (2,900 psig), and/or have a maximum volume of less than 0.1 liter (Article 3, 1.1.(a) first indent, Group 1 fluids). Therefore, these transmitters are not subject to the essential requirements of the directive 97/23/EC (PED, Annex I) and shall not have the CE mark applied.</p> <p>For transmitters rated > 200 bar (2,900 psig) < 1,000 bar (14,500 psig) Honeywell maintains a technical file in accordance with Annex III, Module A, (internal production control) when the CE mark is required. Transmitter Attachments: Diaphragm Seals, Process Flanges and Manifolds comply with Sound Engineering Practice.</p> <p>NOTE: Pressure transmitters that are part of safety equipment for the protection of piping (systems) or vessel(s) from exceeding allowable pressure limits, (equipment with safety functions in accordance with Pressure Equipment Directive 97/23/EC article 1, 2.1.3), require separate examination.</p> <p>A formal statement from TÜV Industry Service Group of TÜV America, Inc., a division of TÜV Süddeutschland, a Notified Body regarding the Pressure Equipment Directive, can be found at www.honeywell.com. A hard copy may be obtained by contacting a Honeywell representative.</p>
<p>CE Mark</p>	<p><i>Electro Magnetic Compatibility (EMC) (2004/108/EC)</i> All Models: EN 50081-1: 1992; EN 50082-2:1995; EN 61326-1:1997 + A1, A2, and A3 – Industrial Locations</p>
<p>Dual Seal Certification</p>	<p>Dual Seal Certification based on ANSI/NFPA 70-202 and ANSI/ISA 12.27.01 requirements without the use of additional seal protection elements.</p>
<p>Measuring Instruments Directive (MID)</p>	<p>Measuring Instruments Directive (MID) (2004/22/EC) Applies only to STA97L (0-100 BAR) and STA94L (0-34.5 BAR) Temperature Range: Class 3 from -25 °C to + 55 °C</p>
<p>Recommended Frequency of Calibration</p>	<p>Honeywell recommends verifying the calibration of these devices once every four years.</p>
<p>Approved Manufacturing Locations</p>	<p>Honeywell Process Solutions - York, PA USA Honeywell (Tianjin) Limited – Tianjin, P.R. China Honeywell Automation India Ltd. – Pune 411013 India</p>

Foundation™ Fieldbus is a trademark of the Fieldbus Foundation.

Viton® is a registered trademark of DuPont

HART® is a registered trademark of HART Communications Foundation.

Teflon® is a registered trademark of DuPont.

Hastelloy® C-276 is a registered trademark of Haynes International.

DC® 200 and DC® 704 are registered trademarks of Dow Corning.

Monel 400® is a registered trademark of Special Metals Corporation.

FM ApprovalsSM is a service mark of FM Global

ST 3000® and Experion® are registered trademarks of Honeywell International Inc.

Mounting

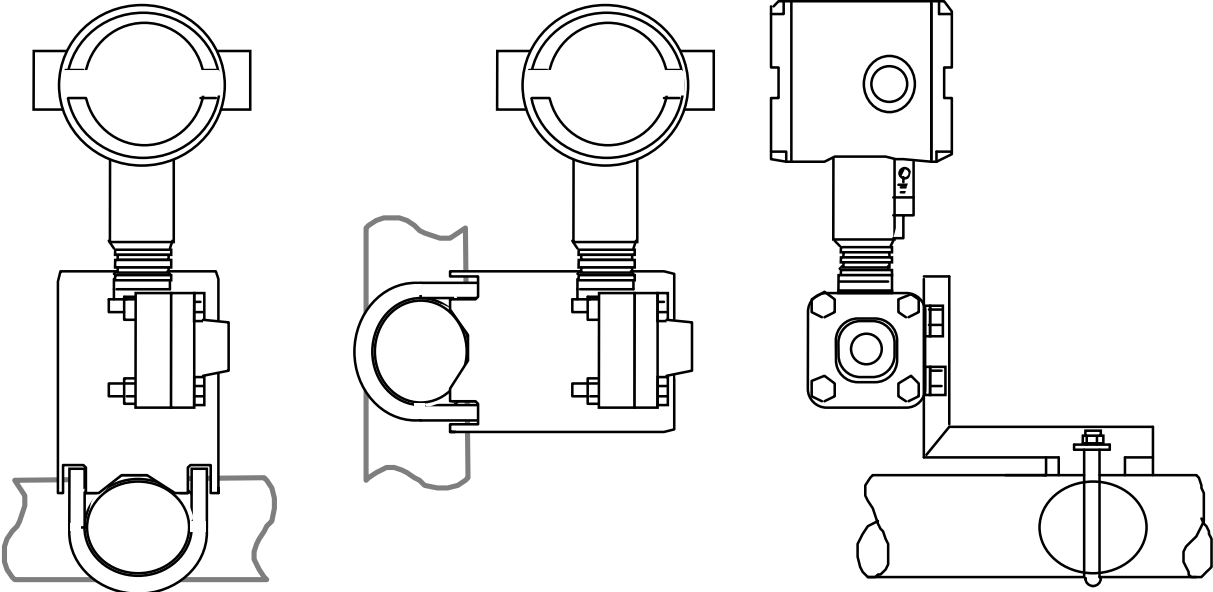

24267

Figure 4 – Examples of typical mounting positions for STA922 and STA940

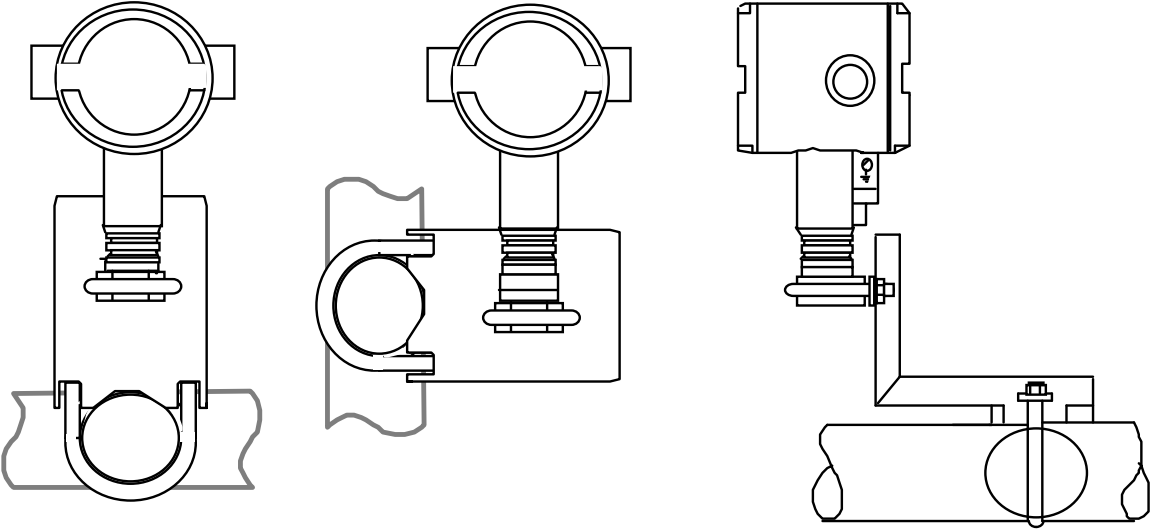

24268

Figure 4a – Examples of typical mounting positions for in-line models STA92L, STA94L and STA97L

Reference Dimensions

millimeters
inches

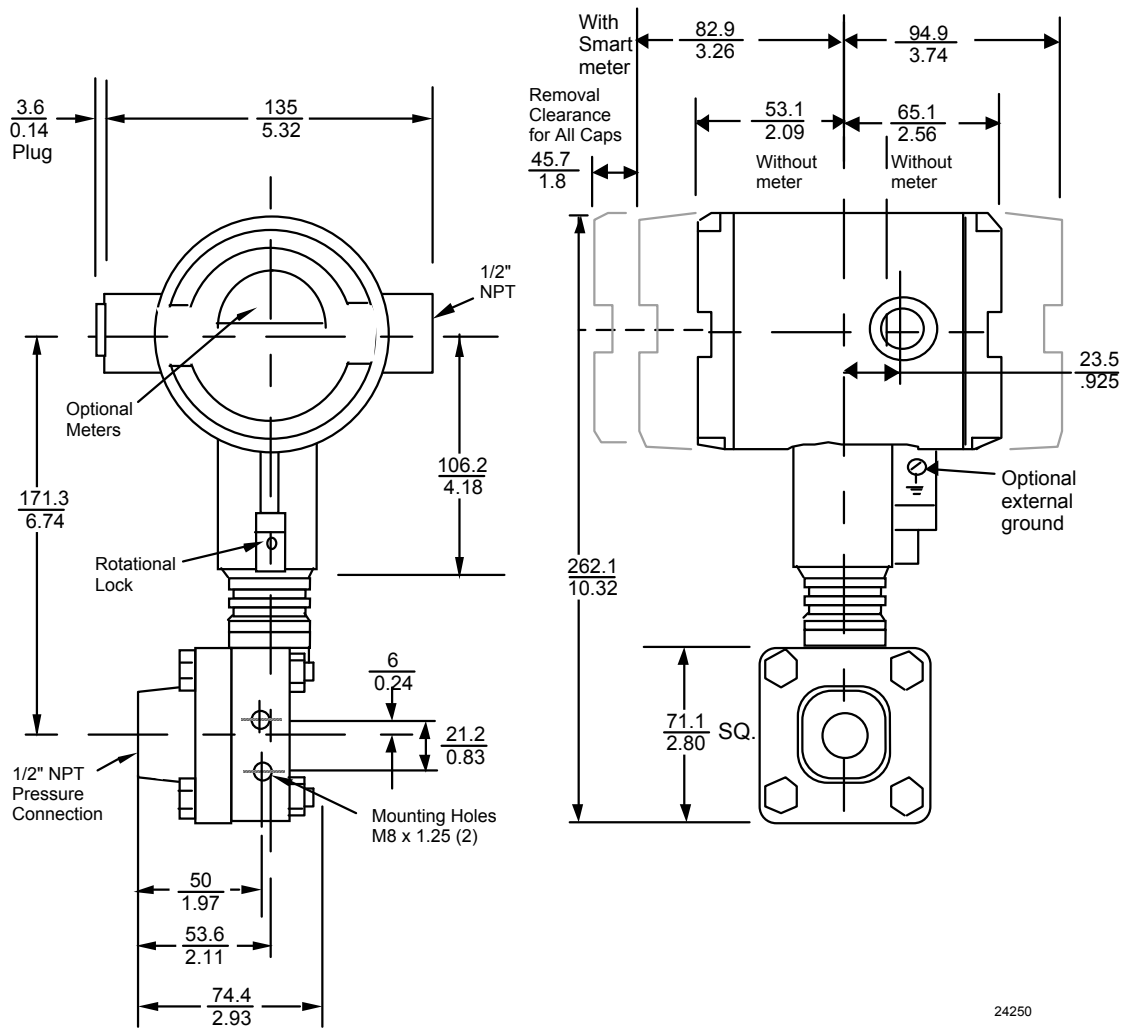

24250

Figure 5 – Typical mounting dimensions for reference STA922 and STA940

Reference Dimensions

millimeters
inches

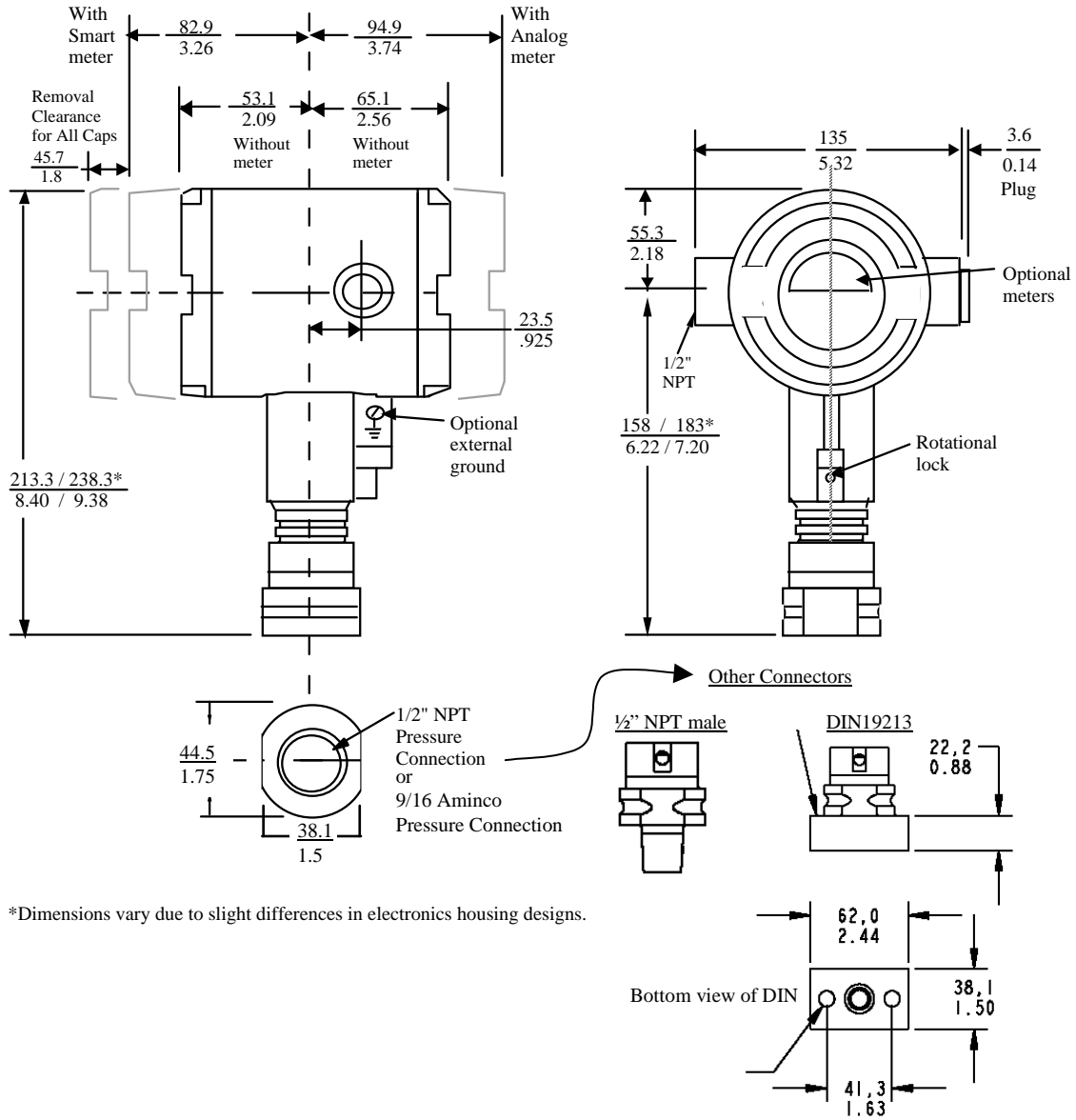

*Dimensions vary due to slight differences in electronics housing designs.

Figure 5a - Typical mounting dimensions for in-line models STA92L, STA94L and STA97L

Options

- **Mounting Bracket (Options MB, MX, SB, SX and FB)**

The angle mounting bracket is available in either zinc-plated carbon steel or stainless steel and is suitable for horizontal or vertical mounting on a two inch (50 millimeter) pipe, as well as wall mounting. An optional flat mounting bracket is also available in carbon steel for two inch (50 millimeter) pipe mounting.

- **Indicating Meter (Options ME and SM)**

Two integral meter options are available. An analog meter (option ME) is available with a 0 to 100% linear scale. The Smart Meter (option SM) provides an LCD display for both analog and digital output and can be configured to display pressure in pre-selected engineering units.

- **HART[®] Protocol Compatibility (Options HC and H6)**

Optional electronics modules for the ST 3000 provide HART Protocol compatibility in either HART 5.x or 6.x formats. Transmitters with a HART Option are compatible with any HART enabled system that provides 5.x or 6.x format support.

- **Foundation[™] Fieldbus (Option FF)**

Equips transmitter with FF protocol for use in 31.25 kbit/s FF networks. See document 34-ST-03-72 for additional information on ST 3000 Fieldbus transmitters.

- **SIL2/SIL3 Certification (Option SL)**

This ST 3000 product is available for use with safety systems. With the SL option, we are fully certified to SIL 2 capability for single transmitters and SIL 3 capability for multiple transmitter use through TÜV Nord Sys Tec GmbH & Co. KG. We are in compliance with the following SIL standards:

IEC 61508-1: 1998

IEC 61508-2: 2000

IEC 61508-3: 1998

- **Lightning Protection (Option LP)**

A terminal block with circuitry that protects the transmitter from transient surges induced by nearby lightning strikes is available.

- **NAMUR NE43 Compliance (Option NE)**

This option provides software that meets the NAMUR NE43 requirements for failsafe software. Transmitter failure information is generated when the measuring information is no longer valid.

Transmitter failure values are: ≤ 3.6 mA and ≥ 21.0 mA. The normal ST 3000 ranges are ≤ 3.8 mA and ≥ 20.5 mA.

- **Indicator Configuration (Option CI)**

Provides custom configuration of Smart Meters.

- **Tagging (Option TG)**

Up to 30 characters can be added on the stainless steel nameplate mounted on the transmitter's electronics housing at no extra cost. Note that a separate nameplate on the meter body contains the serial number and body-related data. A stainless steel wired on tag with additional data of up to 4 lines of 28 characters is also available. The number of characters for tagging includes spaces.

- **Transmitter Configuration (Options TC and FC)**

The factory can configure the transmitter linear/square root extraction, damping time, LRV, URV and mode (analog/digital) and enter an ID tag of up to eight characters and scratchpad information as specified.

- **Custom Calibration and ID in Memory (Option CC)**

The factory can calibrate any range within the scope of the transmitter's range and enter an ID tag of up to eight characters in the transmitter's memory.

Sales and Service

For application assistance, current specifications, pricing, or name of the nearest Authorized Distributor, contact one of the offices below.

**Asia Pacific Global
Technical Support
Field Instruments**

Phone: +65 6580 3156
Fax: +65 6445-3033

Australia

Honeywell Limited
Phone: +(61) 7-3846 1255
FAX: +(61) 7-3840 6481
Toll Free 1300-36-39-36
Toll Free Fax:
1300-36-04-70

China – PRC - Beijing

Honeywell China Inc.
Phone: +(86-10) 8458-3280
Fax: +(86-10) 8458-4650

China – PRC - Shanghai

Honeywell China Inc.
Phone: (86-21) 5257-4568
Fax: (86-21) 6237-2826

China – PRC - Chengdu

Honeywell China Inc.
Phone: +(86-28) 6613-5078
Fax: +(86-28) 8678-7061

China – PRC - Xi'an

Honeywell China Ltd - Xi'an.
Phone: +(86-29) 8833-7490
Fax: +(86-29) 8833-7489

China – PRC - Shenzhen-

Honeywell China Inc.
Phone: +(86) 755-2518-1226
Fax: +(86) 755-2518-1221

Indonesia

PT Honeywell Indonesia
Phone: +(62) 21-535-8833
FAX: +(62) 21-5367 1008

**Honeywell Automation
India Ltd.**

Honeywell Ltd.
Phone: +(91) 6603-9400
Fax: +(91) 6603-9600

Japan

Honeywell Inc.
Phone: +(81) 3 6730 7197
Fax: +(81) 3 6730 7228

Malaysia

Honeywell Engineering
Sdn Bhd
Phone: +(603) 7958-4788
Fax: +(603) 7958-8922

New Zealand

Honeywell Limited
Phone: +(64-9) 623-5050
Fax: +(64-9) 623-5060
Toll Free (0800) 202-088

Singapore

Honeywell Pte Ltd.
Phone: +(65) 6580 3278
Fax: +(65) 6445-3033

South Korea

Honeywell Korea Co Ltd
Phone: +(822) 799 6114
Fax: +(822) 792 9015

Thailand

Honeywell Systems
(Thailand) Ltd.
Phone: +(662) 693-3099
FAX: +(662) 693-3089

Taiwan R.O.C.

Honeywell Taiwan Ltd.
Phone: +(886-2) 2245-1000
FAX: +(886-2) 2245-3243

SE Asia Countries

see Honeywell Pte Ltd
(Singapore)
for: Philippines, Pakistan,
Cambodia, Guam, Laos,
Myanmar, Vietnam,
East Timor

SE Asia Countries

see Honeywell
Automation India Ltd for:
Bangladesh
Nepal
Sri Lanka

EUROPE
Austria

Honeywell Austria GmbH
Phone: +43 (316)400123
FAX: +43 (316)40017

Belgium

Honeywell SA/NV
Phone: +32 (0)2728 24 07
FAX: +32 (0)2728 22 45

Bulgaria

Honeywell EOOD
Phone: +(359) 2 40 20
900
FAX: +(359) 2 40 20 990

Czech Republic

Honeywell spol. s.r.o.
Phone: +420 242 442 232
FAX: +420 242 442 131

Denmark

Honeywell A/S
Phone: +(45) 39 55 55 55
FAX: +(45) 39 55 55 58

Finland

Honeywell OY
Phone: +358 (0)20752 2753
FAX: +358 (0) 20752 2751

France

Honeywell SA
Phone: +33 (0)1 60198075
FAX: +33 (0)1 60198201

Germany

Honeywell AG
Phone: +49 (69)8064-299
FAX: +49 (69)806497336

Hungary

Honeywell Kft.
Phone: +36-1-451 4300
FAX: +36-1-451 4343

Italy

Honeywell S.p.A.
Phone: +390292146307
FAX: +39 0292146377

The Netherlands

Honeywell B.V.
Phone: +31 (0) 20 5656200
FAX: +31 (0) 20 5656210

Norway

Honeywell A/S
Phone: (45) 39 55 55 55

Poland

Honeywell Sp. zo.o
Phone: +48-22-6060900
FAX: +48-22-6060901

Portugal

Honeywell Portugal Lda
Phone: +351 21 424 5000
FAX: +351 21 424 50 99

Romania

Honeywell Bucharest
Phone: +40 (0) 21 2316437
FAX: +40 (0) 21 2316439

Russian Federation (RF),

Honeywell Field Solutions
Kievskaya str., 7,
Moscow 121059, Russia
Phone +7 (495) 796 98 60
Fax +7 (495) 797 99 64

Slovak Republic

Honeywell s.r.o.
Phone: +421-2-58247 410
FAX: +421-2-58247 415

Spain

Honeywell S.A.
Phone: +34 (0)91313 61 00
FAX: +34 (0)91313 61 30

Sweden

Honeywell AB
Phone: +(46) 8 775 55 00
FAX: +(46) 8 775 56 00

Switzerland

Honeywell AG
Phone: +41 18552448
FAX: +(41) 1 855 24 45

Turkey

Honeywell Turkey A.S.
Phone: +90 216 578 71 00
FAX: +90 216 575 66 35

Ukraine

Honeywell
Tel: +380-44-351-15-50
Fax: +380-44-351-15-51

United Kingdom

Honeywell Control Systems
Ltd.
Phone: +44 (0)1344 655251
FAX: +44 (0) 1344 655554

MIDDLE EAST
Abu Dhabi U A E

Middle East Headquarters
Honeywell Middle East Ltd.
Phone: +971 2 4041246
FAX: +971 2 4432536

Sultanate of Oman

Honeywell & Co Oman LLC
Phone: +968 24 701153/
Ext.33
FAX +968 24 787351

Saudia Arabia

Honeywell Turki Arabia Ltd
Jubail Office
Phone: +966-3-341-0140
Fax: +966-3-341-0216
Honeywell - ATCO
Dammam Office
Phone: 0096638304584
Fax: 0096638338059

Kuwait

Honeywell Kuwait KSC
Phone: +965 242 1327 to 30
Fax: +965 242 8315
And
Phone: +965 326
2934/1821Fax: +965 326
1714

AFRICA
**Mediterranean & African
Distributors**

Honeywell SpA
Phone: +39 (02) 250 10 604
FAX: +39 (02) 250 10 659

**South Africa (Republic of)
and sub saharan**

Honeywell Southern Africa
Honeywell S.A. Pty. Ltd.
Phone: +27 11 6958000
FAX +27 118051504

NORTH AMERICA
Canada

Honeywell LTD
Phone: 1-800-737-3360
FAX: 1-800-565-4130

USA

**Honeywell Process
Solutions,
Phone: 1-800-423-9883
Or 1-800-343-0228
Email: ask-ssc@honeywell.com**

SOUTH AMERICA
Argentina

Honeywell S.A.I.C.
Phone: +(54-11) 4383-3637
FAX: +(54-11) 4325-6470

Brazil

Honeywell do Brasil & Cia
Phone: +(55-11) 7266-1900
FAX: +(55-11) 7266-1905

Chile

Honeywell Chile, S.A.
Phone: +(56-2) 233-0688
FAX: +(56-2) 231-6679

Mexico

Honeywell S.A. de C.V.
Phone: +(52) 55 5259-1966
FAX: +(52) 55 5570-2985

Puerto Rico

Honeywell Inc.
Phone: +(809) 792-7075
FAX: +(809) 792-0053

Trinidad

Honeywell Inc.
Phone: +(868) 624-3964
FAX: +(868) 624-3969

Venezuela

Honeywell CA
Phone: +(58-2) 238-0211
FAX: +(58-2) 238-3391

Model Selection Guides are subject to change and are inserted into the specifications as guidance only. Prior to specifying or ordering a model check for the latest revision Model Selection Guides which are published at: <http://hpsweb.honeywell.com/Cultures/en-US/Products/Instrumentation/ProductModelSelectionGuides/default.htm>

Model Selection Guide (34-ST-16-26)



34-ST-16U-26
Issue 56
Page 1 of 5

**ST 3000 Smart Transmitter
Dual Head Gage Pressure (GP) and
Single Head Absolute Pressure (AP)
Series 900**

Model Selection Guide



Instructions

- Select the desired Key Number. The arrow to the right marks the selection available.
- Make one selection from each Table (I, II and IV), using the column below the proper arrow.
- Select as many Table III options as desired plus a required communication option selection.
- A (●) denotes unrestricted availability. A letter denotes restricted availability.
- Restrictions follow Table IV.

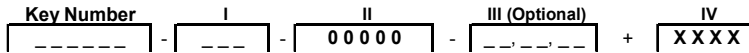

KEY NUMBER

	Span	Selection	Avail.	
Gage Pressure	0-5 to 0-500 psi / 0-.35 to 0-35 bar	STG944	↓	
	0-30 to 0-3,000 psi / 0-2.1 to 0-210 bar	STG974	↓	
Absolute Pressure	0-50 to 0-780 mmHgA / 0-67 to 0-1,040 mbarA	STA922		↓
	0-5 to 0-500 psia / 0-0.35 to 0-35 barA	STA940		↓

Important Note: Base STA and STG models no longer include a default communications option. All units now require the selection of a communication option from Table III (AN, DE, HC, H6 or FF).

TABLE I - METER BODY

	Wetted Process Head ¹³	Vent/Drain Valves ²	Barrier Diaphragms	Selection			
Materials of Construction	Carbon Steel ¹	316 SS	316L SS	A __	●	●	●
	Carbon Steel ¹	316 SS	Hastelloy [®] C-276 ³	B __	●	●	●
	Carbon Steel ¹	316 SS	Monel 400 ^{®4}	C __	19		
	Carbon Steel ¹	316 SS	Tantalum	D __	●		
	316 SS ⁵	316 SS	316L SS	E __	●	●	●
	316 SS ⁵	316 SS	Hastelloy [®] C-276 ³	F __	●	●	●
	316 SS ⁵	316 SS	Monel 400 ^{®4}	G __	19		
	316 SS ⁵	316 SS	Tantalum	H __	●		
	Hastelloy [®] C-276 ^{3,6}	Hastelloy [®] C-276 ³	Hastelloy [®] C-276 ³	J __	●	●	●
	Hastelloy [®] C-276 ^{3,6}	Hastelloy [®] C-276 ³	Tantalum	K __	●		
Monel 400 ^{®4,7}	Monel 400 ^{®9}	Monel 400 ^{®4}	L __	19			
Fill Fluid	Silicone DC ^{®200} ¹⁴			_ 1 _	●	●	●
	CTFE			_ 2 _	●		●
	CTFE (MO)			_ 3 _		●	
Process Head Configuration	1/4 NPT			_ _ A	●		
	1/2 NPT with Adapter			_ _ G	t		
	1/2 NPT			_ _ G		●	●

TABLE II

No Selection	0 0 0 0	●	●	●
--------------	---------	---	---	---

¹ Carbon Steel heads are zinc-plated and not recommended for water service due to hydrogen migration. For that service, use 316 stainless steel Wetted Process Heads.

² Vent/Drains are sealed with Teflon[®] or PTFE

³ Hastelloy[®] C-276 or UNS N10276

⁴ Monel 400[®] or UNS N04400

⁵ Supplied as 316 SS or as Grade CF8M, the casting equivalent of 316 SS.

⁶ Supplied as indicated or as Grade CW12MW, the casting equivalent of Hastelloy[®] C-276

⁷ Supplied as indicated or as Grade M30C, the casting equivalent of Monel 400[®]

⁹ Monel 400[®] or UNS N04400 or UNS N04405

¹³ The standard reference head for the STG9XX is carbon steel (zinc-plated). See Table III for a stainless steel reference (HR) head option.

¹⁴ Use DC[®]704 option when the STA922 will be operating below 50mm HgA, see Fig. 2 in Specification 34-ST-03-65.

Note: End vent drain valve standard for STG9XX. End vent drain valves are not available on STA9XX.

34-ST-16U-26

Issue 56

Page 2 of 5



TABLE III - OPTIONS

Communication Options (Must choose a communications option)	Selection	Availability	Availability	Availability
Analog only (can be configured using appropriate Honeywell DE tool)	AN	•	•	•
DE Protocol communications	DE	•	•	•
HART [®] 5.x Protocol Compatible Electronics	HC	•	•	•
HART [®] 6.x Protocol Compatible Electronics	H6	•	•	•
FOUNDATION [™] Fieldbus Communications	FF	r	r	r
Indicating Meter Options				
Analog Meter (0-100 Even 0-10 Square Root)	ME	•	•	•
Smart Meter	SM	•	•	•
Custom Configuration of Smart Meter	CI	m	m	m
Local Zero	LZ	x		
Local Zero and Span	ZS	s		
Transmitter Housing & Electronics Options				
No housing conduit plugs or adaptors come standard with the ST 3000.				
For certain approval codes, you must select a certified conduit plug from below and it will come packaged in the box with your transmitter.				
316 SS ⁵ Electronics Housing - (with M20 Conduit Connections)	SH	n	n	n
316 SS ⁵ Electronics Housing - (with M20 to 1/2 NPT 316 SS conduit adapter for use with FM and CSA Approval codes)	A3	i	i	i
1/2 NPT Male to M20 Female 316 SS Certified Conduit Adapter (ATEX, CSA & IECEx)	A1	n	n	n
1/2 NPT Male to 3/4 NPT Female 316 SS Certified Conduit Adapter (ATEX, CSA & IECEx)	A2	•	•	•
M20 Male to 1/2 NPT Female 316 SS Certified Conduit Adaptor (ATEX, CSA & IECEx)	A4	•	•	•
1/2 NPT Zinc-plated Certified Conduit Plug (ATEX, CSA & IECEx)	A5	•	•	•
1/2 NPT 316 SS Certified Conduit Plug (ATEX, CSA & IECEx)	A6	•	•	•
M20 316 SS Certified Conduit Plug (ATEX, CSA & IECEx)	A7	•	•	•
1/2 NPT Non-certified Conduit plug (Zinc-plated carbon steel, general use)	A8	•	•	•
NAMUR Failsafe Software	NE	15	15	15
SIL 2 - TÜV Certified transmitter (requires HC/H6 and WP options)	SL	p	p	p
Lightning Protection	LP	•	•	•
Custom Calibration and I.D. in Memory	CC	•	•	•
Transmitter Configuration - (non-Fieldbus)	TC	15	15	15
Transmitter Configuration - (Fieldbus)	FC	21	21	21
Write Protection (Delivered in the "enabled" position)	WP	•	•	•
Write Protection (Delivered in the "disabled" position)	WX	•	•	•
Stainless Steel Customer Wired-On Tag (4 lines, 26 characters per line, customer supplied information)	TG	•	•	•
Stainless Steel Customer Wired-On Tag (blank)	TB	•	•	•
Low Temperature (-50° C Ambient Limit)	LT	z		
Meter Body Options (Seal bolt material depends on Transmitter bolt material)				
A286 SS (NACE) Bolts and 304 SS (NACE) Nuts for Process Heads	CR	•	•	•
316 SS Bolts and 316 SS Nuts for Process Heads	SS	•	•	•
B7M Bolts and Nuts for Process Heads	B7	•		
316 SS ⁵ Adapter Flange - 1/2 NPT with CS Bolts	S2	c		
316 SS ⁵ Adapter Flange - 1/2 NPT with 316 SS Bolts	S3	c		
316 SS ⁵ Adapter Flange - 1/2 NPT with NACE A286 SS Bolts	S4	c		
316 SS ⁵ Adapter Flange - 1/2 NPT with B7M Bolts	S5	c		
Hastelloy [®] C-276 ^{3,6} Adapter Flange - 1/2 NPT with CS Bolts	T2	c		
Hastelloy [®] C-276 ^{3,6} Adapter Flange - 1/2 NPT with 316 SS Bolts	T3	c		
Monel 400 ^{4,7} Adapter Flange - 1/2 NPT with CS Bolts	V2	c		
Monel 400 ^{4,7} Adapter Flange - 1/2 NPT with 316 SS Bolts	V3	c		
316 SS ⁵ Blind Adapter Flange with CS Bolts	B3	•		
316 SS ⁵ Blind Adapter Flange with 316 SS Bolts	B4	•		
316 SS ⁵ Blind Adapter Flange with NACE A286 SS Bolts	B5	•		
316 SS ⁵ Blind Adapter Flange with B7M Bolts	B6	•		
316 SS Center Vent Drain and Bushing	CV	•		
Side Vent/Drain (End Vent Drain is standard)	SV	•		
Viton ^{®8} Process Head Gaskets	VT	•		
Graphite Process Head Gasket	GF	•	•	•
Viton ^{®8} Adapter Flange Gaskets	VF	17		
316 SS Reference Head (Carbon Steel Standard)	HR	•		
Modified DIN Process Heads (316 SS)	DN		v	v

Table III continued next page

³ Hastelloy[®] C-276 or UNS N10276

⁴ Monel 400[®] or UNS N04400

⁵ Supplied as 316 SS or as Grade CF8M, the casting equivalent of 316 SS.

⁶ Supplied as indicated or as Grade CW12MW, the casting equivalent of Hastelloy[®] C-276

⁷ Supplied as indicated or as Grade M30C, the casting equivalent of Monel 400[®]

⁸ Viton[®] or Fluorocarbon Elastomer

34-ST-16U-26
Issue 56
Page 3 of 5

TABLE III - OPTIONS (continued)

	Selection	STG944	STG974	STA922	STA940
Transmitter Mounting Bracket Options					
Angle Mounting Bracket - Carbon Steel	MB	•	•	•	b
Marine Approved Angle Mounting Bracket - Carbon Steel	MX	•	•	•	
Angle Mounting Bracket - 304 SS	SB	•	•	•	
Marine Approved Angle Mounting Bracket - 304 SS	SX	•	•	•	
Flat Mounting Bracket (<i>pipe mounting</i>) - Carbon Steel	FB	•	•	•	
Diaphragm Options					
Gold plated diaphragm(s) on 316 SS	G1	•			b
Gold plated diaphragm(s) on Monel 400 [®] 4 or Hastelloy [®] C-276 ³ ONLY	G2	•			
Services/Certificates/Marine Type Approval Options					
User's Manual Paper Copy (<i>Standard, HC, H6 or FF ships accordingly</i>)	UM	•	•	•	b
Clean Transmitter for Oxygen or Chlorine Service (<i>with Certificate</i>) (50035190)	OX	h	h	h	
Over-Pressure Leak Test (<i>with Certificate</i>) (F3392)	TP	•	•	•	
Calibration Test Report and Certificate of Conformance (F3399)	F1	•	•	•	
Certificate of Conformance (F3391)	F3	•	•	•	
Certificate of Origin (F0195)	F5	•	•	•	
SIL Certificate (<i>SIL 2/3</i>) (FC33337)	FE	22	22	22	
NACE Certificate (<i>Process-Wetted & Non-Process Wetted</i>) (FC33339)	F7	o	o	o	
NACE Certificate (<i>Process-Wetted</i>) (FC33338)	FG	•	•	•	
Material Traceability Certification per EN 10204 3.1 (FC33341)	FX	•	•	•	
Marine Type Approvals (<i>DNV, ABS, BV, KR & LR</i>) (FC33340)	MT	2	2	2	
Warranty Options					
Additional Warranty - 1 year	W1	•	•	•	b
Additional Warranty - 2 years	W2	•	•	•	
Additional Warranty - 3 years	W3	•	•	•	
Additional Warranty - 4 years	W4	•	•	•	

³ Hastelloy[®] C-276 or UNS N10276

⁴ Monel 400[®] or UNS N04400

Approval Body	Approval Type	Location or Classification	Selection			
No hazardous location approvals			9X	•	•	•
FM Approvals SM	Explosion Proof	Class I, Div. 1, Groups A,B,C,D	1C	•	•	•
	Dust-Ignitionproof	Class II, III Div. 1, Groups E,F,G		•	•	•
	Non-Incendive	Class I, Div. 2, Groups A,B,C,D		•	•	•
	Intrinsically Safe	Class I, II, III, Div. 1, Groups A,B,C,D,E,F,G		•	•	•
Canadian Standards Association (CSA)	Explosion Proof	Class I, Div. 1, Groups B,C,D	2J	f	24	24
	Dust-Ignitionproof	Class II, III, Div. 1, Groups E,F,G				
	Intrinsically Safe	Class I, II, III, Div. 1, Groups A,B,C,D,E,F,G				
IECEX	Flameproof, Zone 1	Ex d IIC; T5 (Ta = -40 to +93°C), T6 (Ta = -40 to +78°C)	CA	24	24	24
	Intrinsically Safe, Zone 0/1	Ex ia IIC; T3, T4, T5, T6 (See Spec for detailed temperature codes by Communications option)				
SAEx (South Africa)	Intrinsically Safe, Zone 0/1	Ex ia IIC T4, T5, T6	Z2	•	•	•
	Flameproof, Zone 1	EX d IIC T5, T6 Enclosure IP 66/67	ZD	•	•	•
	Multiple Marking ¹¹ Int. Safe, Zone 0/1, or Flameproof, Zone 1	Ex ia IIC T4, T5, T6 Ex d IIC T5, T6 Enclosure IP 66/67	ZA	•	•	•
CERTUSP INMETRO (Brazil)	Flameproof, Zone 1	BR- Ex d IIC T5, T6	6D	•	•	•
	Intrinsically Safe, Zone 0/1	BR- Ex ia IIC; T4, T5, T6 (See CERTUSP certificate for detailed temperature codes by Communications option)	6S	•	•	•

Approvals continued on next page

¹¹ The user must determine the type of protection required for installation of the equipment. The user shall then check the box [v] adjacent to the type of protection used on the equipment certification nameplate. Once a type of protection has been checked on the nameplate, subsequently the equipment shall not be reinstalled using any of the other certification types.

34-ST-16U-26
 Issue 56
 Page 4 of 5

Approval Body Table (con't)

Approval Body	Approval Type	Location or Classification	Selection	STG944	STG974	STA922	STA940
ATEX ¹⁰ (LCIE)	Intrinsically Safe Zone 0	Ex ia IIC T4 (Ta = -50°C to +93°C); T5 (Ta = -50°C to +85°C); T6 (Ta = -50°C to +70°C) Enclosure IP 66/67	3S	•	•	•	
	Intrinsically Safe, Zone 1	Ex ia IIC T4 (Ta = -50°C to +93°C); T5 (Ta = -50°C to +85°C); T6 (Ta = -50°C to +70°C) Enclosure IP 66/67					
	Dust-tight Enclosure, Zone 0	Ex tD A20 IP6X T95°C (at Ta = 93°C) or T80°C (at Ta = 78°C) Enclosure IP 66/67					
	Flameproof and Dust-tight Enclosure, Zone 1	Ex d IIC T5 (Ta = -40°C to +93°C), T6 (Ta = -40°C to +78°C) Supply 11- 42Vdc Ex tD A21 IP6X T95°C (at Ta = 93°C) or T80°C (at Ta = 78°C) Enclosure IP 66/67	33	24	24	24	
	Non-Sparking, Zone 2	Ex nA, IIC T5 (Ta = -40°C to +93°C), T6 (Ta = -40°C to +78°C); Zone 2 Supply < 42Vdc, 23mA Ex tD A22 IP6X T95°C (at Ta = 93°C) or T80°C (at Ta = 78°C) (Honeywell). Enclosure IP 66/67	3N	•	•	•	
	Multiple Marking ¹¹ Int. Safe, Zone 0/1 and Dust-tight Enclosure, or Flameproof, Zone 1 and Dust-tight Enclosure, or Non-Sparking, Zone 2	Ex ia IIC T4 (Ta = -50°C to +93°C); T5 (Ta = -50°C to +85°C); T6 (Ta = -50°C to +70°C); Ui = 30V; Ii = 100mA Ex tD A20 IP6X T95°C (at Ta = 93°C) or T80°C (at Ta = 78°C) Ex d IIC T5 (Ta = -40°C to +93°C), T6 (Ta = -40°C to +78°C) Supply 11- 42Vdc Ex tD A21 IP6X T95°C (at Ta = 93°C) or T80°C (at Ta = 78°C) Ex nA, IIC T5 (Ta = -40°C to +93°C), T6 (Ta = -40°C to +78°C); Zone 2 Supply < 42Vdc, 23mA Ex tD A22 IP6X T95°C (at Ta = 93°C) or T80°C (at Ta = 78°C) (Honeywell) Enclosure IP 66/67	3C	24	24	24	

¹⁰ See ATEX installation requirements in the ST 3000 User's Manual

¹¹ The user must determine the type of protection required for installation of the equipment. The user shall then check the box [✓] adjacent to the type of protection used on the equipment certification nameplate. Once a type of protection has been checked on the nameplate, subsequently the equipment shall not be reinstalled using any of the other certification types.

TABLE IV	Selection			
Factory Identification	X X X X	•	•	•

34-ST-16U-26
 Issue 56
 Page 5 of 5

RESTRICTIONS

Restriction Letter	Available Only With		Not Available With	
	Table	Selection	Table	Selection
b	Select only one option from this group			
c	I	G		
f	III	This approval code requires the selection of a certified conduit plug: A5, A6 or A7	Key #	STG974
			I	L__
h	I	2		
i	III	1C or 2J		
m	III	SM		
n			III	1C, 2J
o	III	CR, S4, B5		
p	III	HC or H6 and WP	III	FF, 00
r	I	FISCO/FNICO compliance available only with 1C	III	TC, ME, or FISCO/FNICO compliance not available 3C, 3N, 33, 3S, 2J, CA, Z2, ZD, ZA, 6D & 6S
s			III	FF, ME
t	III	Select from Table III S2, S3, S4, S5, T2, T3, V2, V3		
v	I	E_G, F_G		
x	III	FF, SM		
z			Key #	STG974
2	III	MX, SX	III	FB, MB, SB
15			III	FF
17	III	VT		
19			III	F7, FG
21	III	FF		
22	III	SL		
24	III	This approval code requires the selection of a certified conduit plug: A5, A6 or A7		

Ordering Example: STG944-A1A-00000-HC,LP,2J+XXXX

FOUNDATION™ Fieldbus is a trademark of Fieldbus Foundation.
 Viton® is a registered trademark of DuPont Performance Elastomers.
 Teflon® is a registered trademark of DuPont.
 FM ApprovalsSM is a service mark of FM Global
 DC® 200 and DC® 704 are registered trademarks of Dow Corning

Model Selection Guides are subject to change and are inserted into the specifications as guidance only. Prior to specifying or ordering a model check for the latest revision Model Selection Guides which are published at: <http://hpsweb.honeywell.com/Cultures/en-US/Products/Instrumentation/ProductModelSelectionGuides/default.htm>

Model Selection Guide (34-ST-16-28)



34-ST-16U-28
Issue 49
Page 1 of 5

**ST 3000 Smart Transmitter
In-Line Gage & Absolute Pressure
Series 900**

Model Selection Guide



Instructions

- Select the desired Key Number. The arrow to the right marks the selection available.
- Make one selection from each Table (I, II and IV), using the column below the proper arrow.
- Select as many Table III options as desired plus a communications option selection.
- A (●) denotes unrestricted availability. A letter denotes restricted availability.
- Restrictions follow Table IV.

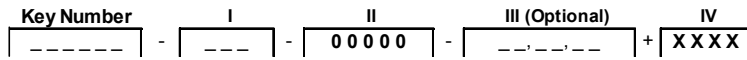

KEY NUMBER

	Span	Selection	Avail.
Gage Pressure	0-5 to 0-500 psig / 0-0.35 to 0-35 bar	STG94L	↓
	0-30 to 0-3,000 psig / 0-2.1 to 0-210 bar	STG97L	↓
	0-60 to 0-6,000 psig / 0-4.1 to 0-415 bar	STG98L	↓
	0-100 to 0-10,000 psig / 0-7 to 0-690 bar	STG99L	↓
Absolute Pressure	0-50 to 0-780 mmHg / 0-67 to 0-1,040 mbarA	STA92L	↓
	0-5 to 0-500 psia / 0-0.35 to 0-35 barA	STA94L	↓
	0-30 to 0-3,000 psia / 0-2.1 to 0-210 barA	STA97L	↓

Important Note: Base STA and STG models no longer include a default communications option. All units now require the selection of a communication option from Table III (AN, DE, HC, H6 or FF).

TABLE I - METER BODY

	Wetted Process Heads	Vent/Drain Valves ¹	Barrier Diaphragms	Selection		
Materials of Construction	316 SS	--	316L SS	E__	●	●
	316 SS	--	Hastelloy [®] C-276 ²	F__	●	●
Fill Fluid	DC [®] 200 Silicone			_1_	●	●
	CTFE			_2_	●	●
Process Connection Configuration	9/16" - 18 Aminco			__A	●	●
	1/2 NPT (female)			__G	●	●
	1/2 NPT (male)			__H	●	●
	DIN 19213			__D	●	●

TABLE II

No Selection	00000	●	●
--------------	-------	---	---

¹ Vent/Drains are sealed with Teflon[®] or PTFE
² Hastelloy[®] C-276 or UNS N10276

Ordering Example: STG94L-E1A-00000-AN,9X+XXXX

34-ST-16U-28
 Issue 49
 Page 2 of 5

TABLE III - OPTIONS	Selection	Availability	
		STG9_L STA9_L	STG99 L
Communication Options (Must choose a communications option)			
Analog only (can be configured using appropriate Honeywell DE tool)	AN	•	•
DE Protocol communications	DE	•	•
HART® 5.x Protocol Compatible Electronics	HC	•	•
HART® 6.x Protocol Compatible Electronics	H6	•	•
FOUNDATION™ Fieldbus Communications	FF	r	r
Indicating Meter Options			
Analog Meter (0-100 Even 0-10 Square Root)	ME	•	•
Smart Meter	SM	•	•
Custom Configuration of Smart Meter	CI	m	m
Local Zero	LZ	x	x
Local Zero and Span	ZS	s	s
Transmitter Housing & Electronics Options			
No housing conduit plugs or adaptors come standard with the ST 3000.			
For certain approval codes, you must select a certified conduit plug from below and it will come packaged in the box with your transmitter.			
316 SS ³ Electronics Housing - (with M20 Conduit Connections)	SH	n	n
316 SS ³ Electronics Housing - (with M20 to 1/2 NPT 316 SS conduit adapter for use with FM and CSA Approval codes)	A3	i	i
1/2 NPT Male to M20 Female 316 SS Certified Conduit Adapter (ATEX, CSA & IECEx)	A1	•	•
1/2 NPT Male to 3/4 NPT Female 316 SS Certified Conduit Adapter (ATEX, CSA & IECEx)	A2	•	•
M20 Male to 1/2 NPT Female 316 SS Certified Conduit Adaptor (ATEX, CSA & IECEx)	A4	•	•
1/2 NPT Zinc-plated Certified Conduit Plug (ATEX, CSA & IECEx)	A5	•	•
1/2 NPT 316 SS Certified Conduit Plug (ATEX, CSA & IECEx)	A6	•	•
M20 316 SS Certified Conduit Plug (ATEX, CSA & IECEx)	A7	•	•
1/2 NPT Non-certified Conduit plug (Zinc-plated carbon steel, general use)	A8	•	•
NAMUR Failsafe Software	NE	15	15
SIL 2 - TÜV Certified transmitter (requires HC or H6 and WP options)	SL	p	p
Lightning Protection	LP	•	•
Custom Calibration and I.D. in Memory	CC	•	•
Transmitter Configuration - (non-Fieldbus)	TC	15	15
Transmitter Configuration - (Fieldbus)	FC	21	21
Write Protection (Delivered in the "enabled" position)	WP	•	•
Write Protection (Delivered in the "disabled" position)	WX	•	•
Stainless Steel Customer Wired-On Tag (4 lines, 26 characters per line, customer supplied information)	TG	•	•
Stainless Steel Customer Wired-On Tag (blank)	TB	•	•
Low Temperature (-50°C Ambient Limit)	LT	18	18
Transmitter Mounting Bracket Options			
Angle Mounting Bracket - Carbon Steel	MB	•	•
Marine Approved Angle Mounting Bracket - Carbon Steel	MX	•	•
Angle Mounting Bracket - 304 SS	SB	•	•
Marine Approved Angle Mounting Bracket - 304 SS	SX	•	•
Flat Mounting Bracket - Carbon Steel	FB	•	•
Services/Certificates/Marine Type Approval Options			
User's Manual Paper Copy (Standard, HC, H6, or FF ships accordingly)	UM	•	•
Clean Transmitter for Oxygen or Chlorine Service with Certificate (50039190)	OX	h	h
Over-Pressure Leak Test with Certificate (F3392)	TP	•	•
Calibration Test Report and Certificate of Conformance (F3399)	F1	•	•
Certificate of Conformance (F3391)	F3	•	•
Certificate of Origin (F0195)	F5	•	•
SIL Certificate (SIL 2/3) (FC33337)	FE	22	22
NACE Certificate (Process-Wetted & Non-Process Wetted) (FC33339)	F7	•	•
NACE Certificate (Process-Wetted only) (FC33338)	FG	•	•
Material Traceability Certification per EN 10204 3.1 (FC33341)	FX	•	•
Marine Type Approvals (DNV, ABS, BV, KR & LR) (FC33340)	MT	2	2
Warranty Options			
Additional Warranty - 1 year	W1	•	•
Additional Warranty - 2 years	W2	•	•
Additional Warranty - 3 years	W3	•	•
Additional Warranty - 4 years	W4	•	•

Table III continued next page

³ Supplied as 316 SS or as Grade CF8M, the casting equivalent of 316 SS.

TABLE III - OPTIONS (continued)				Availability	STG99L
Approval Body	Approval Type	Location or Classification	Selection	STG9_L STA9_L	STG99L
No hazardous location approvals			9X	•	•
FM Approvals SM	Explosion Proof	Class I, Div. 1, Groups A,B,C,D	1C	•	•
	Dust-Ignitionproof	Class II, III Div. 1, Groups E,F,G			
	Non-Incendive	Class I, Div. 2, Groups A,B,C,D			
	Intrinsically Safe	Class I, II, III, Div. 1, Groups A,B,C,D,E,F,G			
ATEX ¹⁰ (LCIE)	Intrinsically Safe, Zone 0	Ex II 1 G Ex ia IIC T4 (Ta = -50°C to +93°C); T5 (Ta = -50°C to +85°C); T6 (Ta = -50°C to +70°C) Enclosure IP 66/67	3S	•	•
	Intrinsically Safe, Zone 1	Ex II 2 G Ex ia IIC T4 (Ta = -50°C to +93°C); T5 (Ta = -50°C to +85°C); T6 (Ta = -50°C to +70°C) Enclosure IP 66/67	33	24	24
	Dust-tight Enclosure, Zone 0	Ex II 1 D Ex td A20 IP6X T95°C (at Ta = 93°C) or T80°C (at Ta = 78°C) Enclosure IP 66/67			
	Flameproof and Dust-tight Enclosure, Zone 1	Ex II 2 GD Ex d IIC T5 (Ta = -40°C to +93°C), T6 (Ta = -40°C to +78°C) Supply 11- 42Vdc Ex td A21 IP6X T95°C (at Ta = 93°C) or T80°C (at Ta = 78°C) Enclosure IP 66/67			
	Non-Sparking, Zone 2	Ex II 3 G Ex nA, IIC T5 (Ta = -40°C to +93°C), T6 (Ta = -40°C to +78°C); Zone 2 Supply < 42Vdc, 23mA Ex td A22 IP6X T95°C (at Ta = 93°C) or T80°C (at Ta = 78°C) (Honeywell). Enclosure IP 66/67	3N	•	•
	Multiple Marking ¹¹ Int. Safe, Zone 0/1 and Dust-tight Enclosure, or Flameproof, Zone 1 and Dust-tight Enclosure, or Non-Sparking, Zone 2	Ex II 1 GD Ex ia IIC T4 (Ta = -50°C to +93°C); T5 (Ta = -50°C to +85°C); T6 (Ta = -50°C to +70°C); Ui = 30V; li = 100mA Ex td A20 IP6X T95°C (at Ta = 93°C) or T80°C (at Ta = 78°C)	3C	24	24
Ex II 2 GD Ex d IIC T5 (Ta = -40°C to +93°C), T6 (Ta = -40°C to +78°C) Supply 11- 42Vdc Ex td A21 IP6X T95°C (at Ta = 93°C) or T80°C (at Ta = 78°C)					
Ex II 3 GD Ex nA, IIC T5 (Ta = -40°C to +93°C), T6 (Ta = -40°C to +78°C); Zone 2 Supply < 42Vdc, 23mA Ex td A22 IP6X T95°C (at Ta = 93°C) or T80°C (at Ta = 78°C) (Honeywell) Enclosure IP 66/67					

Table III Approvals continued next page

34-ST-16U-28

Issue 49

Page 4 of 5

TABLE III - OPTIONS (continued)

Approval Body	Approval Type	Location or Classification	Selection	STG9_L STA9_L	STG99L
Canadian Standards Association (CSA)	Explosion Proof	Class I, Div. 1, Groups B,C,D	2J	3	4
	Dust-Ignitionproof	Class II, III, Div. 1, Groups E,F,G			
	Intrinsically Safe	Class I, II, III, Div. 1, Groups A,B,C,D,E,F,G			
IECEX	Flameproof, Zone 1	Ex d IIC T5 (Ta = -40 to +93°C), T6 (Ta = -40 to +78°C)	CA	24	24
	Intrinsically Safe, Zone 0/1	Ex ia IIC ; T3, T4, T5, T6 See Spec for detailed temperature codes by Communications option			
SAEx (South Africa)	Intrinsically Safe, Zone 0/1	Ex ia IIC T4, T5, T6	Z2	•	•
	Flameproof, Zone 1	Ex d IIC T5, T6 Enclosure IP 66/67	ZD	•	•
	Multiple Marking ¹¹ Int. Safe, Zone 0/1, or Flameproof, Zone 1	Ex ia IIC T4, T5, T6 Ex d IIC T5, T6 Enclosure IP 66/67	ZA	•	•
CERTUSP INMETRO (Brazil)	Flameproof, Zone 1	BR- Ex d IIC T5, T6	6D	•	•
	Intrinsically Safe, Zone 0/1	BR- Ex ia IIC ; T4, T5, T6 (See CERTUSP certificate for detailed temperature codes by Communications option)	6S	•	•

¹⁰ See ATEX installation requirements in the ST 3000 User's Manual

¹¹ The user must determine the type of protection required for installation of the equipment. The user shall then check the box [✓] adjacent to the type of protection used on the equipment certification nameplate. Once a type of protection has been checked on the nameplate, subsequently the equipment shall not be reinstalled using any of the other certification types.

TABLE IV

	Selection		
Factory Identification	X X X X	•	•

RESTRICTIONS

Restriction Letter	Available Only With		Not Available With	
	Table	Selection	Table	Selection
b	Select only one option from this group			
h	I	_ 2 _		
i	III	1C or 2J		
m	III	SM		
n			III	1C, 2J
p	III	HC or H6 and WP	III	FF
r	III	FISCO/FNICO compliance available only with 1C	III	TC, ME or FISCO/FNICO compliance not available with 3C, 3N, 33, 3S, 2J, CA, Z2, ZD, ZA, 6D & 6S
s			III	STA92L, STA94L, FF, ME
x	III	FF, SM		
2	III	MX, SX	III	FB, MB, SB
3		This approval code requires the selection of a certified conduit plug: A5, A6 or A7	Key #	STA92L or STA94L
4		This approval code requires the selection of a certified conduit plug: A5, A6 or A7	III	No CRN Number Available
15			III	FF
18	I	_ 1 _		
21	III	FF		
22	III	SL		
24	III	This approval code <u>requires</u> the selection of a certified conduit plug: A5, A6 or A7		

Hastelloy® is a registered trademark of Haynes International

Monel 400® is a registered trademark of Special Metals Corporation.

HART® is a registered trademark of HART Communication Foundation.

FOUNDATION™ Fieldbus is a registered trademark of Fieldbus Foundation.

Viton® is a registered trademark of DuPont Performance Elastomers.

Teflon® is a registered trademark of DuPont.

FM ApprovalsSM is a service mark of FM Global

DC® 200 is a registered trademark of Dow Corning

Specifications are subject to change without notice.

For More Information

Learn more about how Honeywell's ST 3000 Series 900 Absolute Pressure Transmitters can increase performance, reduce downtime and decrease configuration costs, visit our website www.honeywell.com/ps/hfs or contact your Honeywell account manager.

Honeywell Process Solutions

1860 West Rose Garden Lane
Phoenix, Arizona 85027
Tel: 1-800-423-9883 or 1-800-343-0228
www.honeywell.com/ps

34-ST-03-66
August 2011
©2010 Honeywell International Inc.

The Honeywell logo is displayed in a bold, red, sans-serif font.