

ST 3000 Smart Transmitter Series 100 High Temperature Models Specifications

34-ST-03-70 April 2011



Introduction

In 1983, Honeywell introduced the first Smart Pressure Transmitter—the ST 3000®. In 1989, Honeywell launched the first all digital, bi-directional protocol for smart field devices. Today, Honeywell transmitters demonstrate proven reliability in hundreds on installations in a wide variety of industries and applications. Applications include gauge pressure for reaction vessels in the chemical industry as well as level applications in both the chemical and hydrocarbon processing industries with a relatively high process temperature of 302°F (150°C).

| Models | | |
|--------|---------------|--------------|
| STG14T | 0 to 500 psig | 0 to 35 barg |
| STF14T | 0 to 500 psig | 0 to 35 barg |

All ST 3000 transmitters can be ordered to provide one of the following output communication options.

| Communications options |
|-----------------------------------|
| 4-20 mA |
| Honeywell Digitally Enhanced (DE) |
| HART® (versions 5.x or 6.x) |
| FOUNDATION™ Fieldbus |

When digitally integrated with Honeywell's Process Knowledge System™, EXPERION PKS™, ST 3000 instruments provide a more accurate process variable as well as advanced diagnostics.

The devices provide comprehensive self-diagnostics to help users maintain high uptime, meet regulatory requirements, and attain high quality standards. Series 100 transmitters are ideal for critical applications, such as custody transfer of natural gas and energy and material balances, where accuracy and stability are of the utmost importance.



Figure 1—

STG14T Series 100 High Temperature GP Transmitters which features proven piezoresistive sensor technology.

Honeywell's high-performance ST 3000 S100 transmitters lead the industry in:

- Accuracy
- Stability
- Reliability
- Rangeability
- Warranty

| ST 3000 S100 Transmitter Benefits |
|-----------------------------------|
| Total Accuracy = ±0.0375% |
| Stability = ±0.01% per year |
| Reliability = 470 years MTBF |
| Rangeability = 400 to 1 |
| Lifetime Warranty = 15 years |

Description

The ST 3000 transmitter can replace any 4 to 20 mA output transmitter in use today and operates over a standard two-wire system.

The measuring means is a piezoresistive sensor, which actually contains three sensors in one. It contains a differential pressure sensor, a temperature sensor, and a static pressure sensor.

Microprocessor-based electronics provide higher span-turndown ratio, improved temperature and pressure compensation, and improved accuracy.

The transmitter's meter body and electronics housing resist shock, vibration, corrosion, and moisture. The electronics housing contains a compartment for the single-board electronics, which is isolated from an integral junction box. The single-board electronics is replaceable and interchangeable with any other ST 3000 Series 100 or Series 900 model transmitters.

Like other Honeywell transmitters, the ST 3000 features two-way communication and configuration capability between the operator and the transmitter through several Honeywell field-rated portable configuration devices, including the Smart Field Communicator (SFC) and the Multiple Communication Configurator (MC ToolKit). While both are made for in-field use, the MC Toolkit also can be ordered for use in intrinsically safe environments.

The SCT 3000 Smartline® Configuration Toolkit provides an easy way to configure instruments using a personal computer. The toolkit enables configuration of devices before shipping or installation. The SCT 3000 can operate in the offline mode to configure an unlimited number of devices. The database can then be loaded down-line during commissioning.

Features

- Choice of linear or square root output conformity is a simple configuration selection.
 - Direct digital integration with Experion PKS and other control systems provides local measurement accuracy to the system level without adding typical A/D and D/A converter inaccuracies.
- Unique piezoresistive sensor automatically compensates input for temperature and static pressure. Added "smart" features include configuring lower and upper range values, simulating accurate analog output, and selecting preprogrammed engineering units for display.
- Smart transmitter capabilities with local or remote interfacing means significant manpower efficiency improvements in commissioning, start-up, and ongoing maintenance functions.

Advanced Diagnostics

ST 3000 is now available for both HART® 6 and Foundation™ Fieldbus with advanced diagnostics that minimize unplanned plant outages, minimize maintenance costs and by providing the industry's most reliable transmitter.

- Provide advanced warning of possible failure events and avoid costly shutdowns.
- Three levels of failure reporting
- Comprehensive list of on-board diagnostics (Ref. ST 3000 User manual with HART® 6, 34-ST-25-17 Rev: June 09 and Foundation™ Fieldbus option manual 34-ST-25-15 Rev: June 09)

Tank Level Measurement Application

Pressure transmitters are commonly used to measure the level in an open or non-pressurized tank. See Figure 2. The level is directly proportional to the DP (H1) measurement, by the relationship:

$$\text{Level} = H1 \times \text{SGp}$$

Where,

SGp = specific gravity of process fluid.

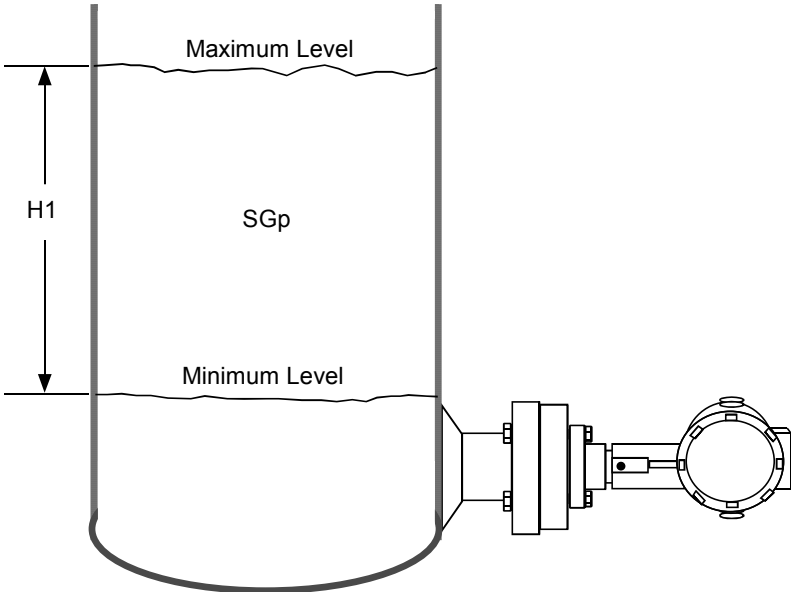

Figure 2 —Tank Level Measurement. Small Flange shown.

Operating Conditions – All Models

| Parameter | Reference Condition | | Rated Condition | | Operative Limits | | Transportation and Storage | |
|---|---|------|---------------------|------------|------------------------------|------------|----------------------------|------------|
| | °C | °F | °C | °F | °C | °F | °C | °F |
| DC[®] 200 Silicone Fill Fluid | | | | | | | | |
| Ambient Temperature | 25±1 | 77±2 | -40 to 85 | -40 to 185 | -40 to 93 | -40 to 200 | -55 to 125 | -67 to 257 |
| Process Interface Temperature | 25±1 | 77±2 | -40 to 150 | -40 to 302 | -40 to 150 | -40 to 302 | NA | NA |
| Neobee[®] M-20 Fill Fluid | | | | | | | | |
| Ambient Temperature | 25±1 | 77±2 | -15 to 75 | 5 to 167 | -15 to 75 | 5 to 167 | -15 to 75 | 5 to 167 |
| Process Interface Temperature | 25±1 | 77±2 | -15 to 110 | 5 to 230 | -15 to 110 | 5 to 230 | NA | NA |
| Humidity %RH | 10 to 55 | | 0 to 100 | | 0 to 100 | | 0 to 100 | |
| Maximum Allowable Working Pressure (MAWP) | | | MAWP | | | | | |
| Threaded | | | 500 psig (34.5 bar) | | | | | |
| Flanged | | | | | | | | |
| ANSI Class 150 psi bar | | | 275(2) 19 (2) | | | | | |
| ANSI Class 300 psi bar | | | 500 34.5 | | | | | |
| Vacuum Region – Minimum Pressure | | | | | | | | |
| mmHg absolute | Atmospheric | | 300 ¹ | | 2 (short term ²) | | | |
| inH ₂ O absolute | Atmospheric | | 150 | | 1 (short term ²) | | | |
| Supply Voltage, Current, and Load Resistance | Voltage Range: 10.8 to 42.4 Vdc at terminals Current Range: 3.8 to 21.8 mA Load Resistance: 0 to 1,440 ohms (as shown in Figure 3) | | | | | | | |

¹ Limit is 600 mmHg absolute (321 inH₂O absolute) for Neobee fill

² Short term equals 2 hours at 70 °C (158 °F).

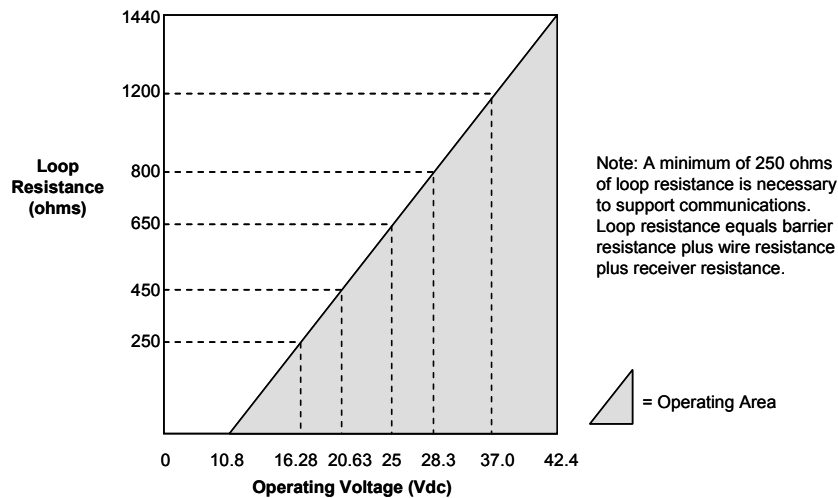

Figure 3—Supply Voltage and Loop Resistance Chart.

Ambient Temperature De-rating

| DC[®] 200 Silicone Fill Fluid | | Neobee[®] M-20 Fill Fluid | |
|--|----------------------------------|---|----------------------------------|
| Process temperatures above 125°C (257°F) require de-rating the ambient limit as follows: | | Process temperatures above 85°C (185°F) require de-rating the ambient limit as follows: | |
| Process Temperature | Ambient Temperature Limit | Process Temperature | Ambient Temperature Limit |
| 150°C (302°F) | 50°C (122°F) | 110°C (230°F) | 50°C (122°F) |
| 140°C (284°F) | 60°C (140°F) | 100°C (212°F) | 60°C (140°F) |
| 125°C (257°F) | 85°C (185°F) | 85°C (185°F) | 75°C (167°F) |

Performance Under Rated Conditions* - Models STG14T and STF14T 0-500 psig (0-35 barg)

| Parameter | Description |
|---|--|
| Upper Range Limit** | psig barg 500 35 |
| Minimum Span | psig barg 0.9 0.063 |
| Turndown Ratio | 550 to 1 |
| Zero Elevation and Suppression | No limit except minimum span from absolute zero to 100% of URL. Specifications valid over this range. |
| Accuracy (Reference – Includes combined effects of linearity, hysteresis, and repeatability) <ul style="list-style-type: none"> Accuracy includes residual error after averaging successive readings. For FOUNDATION[™] Fieldbus use Digital Mode specifications. For HART[®] use Analog Mode specifications. | In Analog Mode: ±0.0875% of calibrated span or upper range value (URV), whichever is greater. For URV below reference point (20 psi), accuracy equals: $\pm \left[0.025 + 0.0625 \left(\frac{20 \text{ psi}}{\text{span psi}} \right) \right] \text{ or } \pm \left[0.025 + 0.0625 \left(\frac{1.4 \text{ bar}}{\text{span bar}} \right) \right] \text{ in \% of span}$ In Digital Mode: ±0.075% of calibrated span or upper range value (URV), whichever is greater. For URV below reference point (20 psi), accuracy equals: $\pm \left[0.0125 + 0.0625 \left(\frac{20 \text{ psi}}{\text{span psi}} \right) \right] \text{ or } \pm \left[0.0125 + 0.0625 \left(\frac{1.4 \text{ bar}}{\text{span bar}} \right) \right] \text{ in \% of span}$ |
| Zero Temperature Effect per 28°C (50°F) | In Analog Mode: ±0.0625% of calibrated span. For URV below reference point (50 psi), effect equals: $\pm \left[0.0125 + 0.05 \left(\frac{50 \text{ psi}}{\text{span psi}} \right) \right] \text{ or } \pm \left[0.0125 + 0.05 \left(\frac{3.5 \text{ bar}}{\text{span bar}} \right) \right] \text{ in \% of span}$ In Digital Mode: ±0.05% of calibrated span For URV below reference point (50 psi), effect equals: $\pm 0.05 \left(\frac{50 \text{ psi}}{\text{span psi}} \right) \text{ or } \pm 0.05 \left(\frac{3.5 \text{ bar}}{\text{span bar}} \right) \text{ in \% of span}$ |
| Combined Zero and Span Temperature Effect per 28°C (50°F) | In Analog Mode: ±0.10% of calibrated span. For URV below reference point (50 psi), effect equals: $\pm \left[0.05 + 0.05 \left(\frac{50 \text{ psi}}{\text{span psi}} \right) \right] \text{ or } \pm \left[0.05 + 0.05 \left(\frac{3.5 \text{ bar}}{\text{span bar}} \right) \right] \text{ in \% of span}$ In Digital Mode: ±0.075% of calibrated span For URV below reference point (50 psi), effect equals: $\pm \left[0.025 + 0.05 \left(\frac{50 \text{ psi}}{\text{span psi}} \right) \right] \text{ or } \pm \left[0.025 + 0.05 \left(\frac{3.5 \text{ bar}}{\text{span bar}} \right) \right] \text{ in \% of span}$ |
| Stability | ±0.04% of URL per year |

* Performance specifications are based on reference conditions of 25°C (77°F), 10 to 55% RH, and 316L SS diaphragm.

** Transmitter URL limit or maximum process connection rating, whichever is lower.

Performance Under Rated Conditions – All Models

| Parameter | Description |
|---|---|
| Output (two-wire) | Analog 4 to 20 mA or digital communications DE mode. Options available for Foundation™ Fieldbus and HART® protocol. |
| Supply Voltage Effect | ±0.005% of span per volt. |
| Damping Time Constant | Adjustable from 0 to 32 seconds digital damping. |
| EMC Classification | Group 1, Class A, ISM Equipment (EN 55011, emissions), Industrial Equipment (EN 50082-2, immunity). |
| CE Conformity (Europe) | 89/336/EEC, Electromagnetic Compatibility (EMC) Directive. |
| NAMUR NE 43 Compliance (Option “NE”) | Transmitter failure information is generated when the measuring information is invalid or no longer present. Failure information is transmitted as a current signal but outside the normal 4-20 mA measurement signal level. Transmitter failure values are: ≤ 3.6 mA and ≥ 21.0 mA. The normal signal range is ≥ 3.8 mA and ≤ 20.5 mA. |
| SIL 2/3 Compliance | SIL certified to IEC 61508 for non-redundant use in SIL 2 related Safety Systems (single use) and for redundant (multiple) use in SIL 3 Safety Systems through TÜV Nord Sys Tec GmbH & Co. KG under the following standards: IEC61508-1: 1998; IEC 61508-2: 2000; IEC61508-3: 1998. |
| Lightning Protection Option (Code “LP”) | Leakage Current: 10 microamps max. @ 42.4 VDC, 93°C Impulse Rating: 10/20 µ sec. 5,000 Amps (50 strikes) 10,000 Amps (20 strikes) (rise/decay) 10/1,000 µ sec. 250 Amps (1,000 strikes) 500 Amps (400 strikes) |

Physical and Approval Bodies

| Parameter | Description |
|--------------------------------|---|
| Process Connections | Process Head: 1/2-inch NPT. Flange: 1/2", 1", 1 1/2" and 2" 150# or 300# ANSI flange |
| Diaphragm Materials (wetted) | 316L Stainless Steel |
| Gasket Ring Materials (wetted) | 316L Stainless Steel |
| Mounting Flange (non-wetted) | 316 Stainless Steel |
| Process Head Gasket | Teflon® is standard. Viton® is optional. |
| Fill Fluid | DC® 200 Silicone or Neobee® (M20) |
| Electronic Housing | Epoxy-Polyester hybrid paint. Low copper-aluminum alloy. Meets NEMA type 4X (watertight) and designed to meet NEMA 7 (explosion proof). |
| Process Connections | Process Head: 1/2-inch NPT. Flange: 1/2", 1", 1 1/2" and 2" 150# or 300# ANSI flange |
| Wiring | Accepts up to 16 AWG (1.5 mm diameter). |
| Mounting | 1/2-inch NPT or flange mount connection. |
| Dimensions | See Figure 4 and Figure 5. |
| Net Weight | 7 pounds (3.2 Kg) to 15 pounds (7 Kg). |

NOTE: Pressure transmitters that are part of safety equipment for the protection of piping (systems) or vessel(s) from exceeding allowable pressure limits, (equipment with safety functions in accordance with Pressure Equipment Directive 97/23/EC article 1, 2.1.3), require separate examination.

Certifications

| | Type of Protection | Comm. Option | Field Parameters | Temp. Codes |
|----------------------------------|--|-------------------------------|--|------------------------------|
| FM ApprovalsSM | Explosionproof: Class I, Division 1, Groups A, B, C, D locations Dust Ignition Proof: Class II, III, Division 1, Groups E, F, G locations, Enclosure Type 4X | All | All | T5 Ta = 93°C |
| | Intrinsically Safe: Class I, II, III, Division 1, Groups A, B, C, D, E, F, G locations, Enclosure Type 4X | 4-20 mA / DE | Vmax = 42.4V Imax = 225mA Ci = 4.2nF Li = * Pi = 1.2W | T4 Ta = 93°C |
| | | 4-20 mA / | Vmax = 30V Imax = 225mA Ci = 4.2nF Li = * Pi = 1.2W | T4 Ta = 93°C |
| | Intrinsically Safe: Class I, II, III, Division 1, Groups A, B, C, D, E, F, G locations; Class 1, Zone 0, AEx ia Group IIC, Enclosure Type 4X / IP 66/67 | Fieldbus – Entity (Not FISCO) | Vmax = 32V Imax = 120mA Ci = 4.2nF Li = 0 Pi = 0.84W | T4 Ta = 40°C T3 Ta = 93°C |
| | | Fieldbus – Entity (Not FISCO) | Vmax = 24V Imax = 250mA Ci = 4.2nF Li = 0 Pi = 1.2W | T4 Ta = 40°C T3 Ta = 93°C |
| | | FISCO | Vmax = 17.5V Imax = 380mA Ci = 4.2nF Li = 0 Pi = 5.32W | T4 Ta = 40°C T3 Ta = 93°C |
| | Nonincendive: Class I, Division 2, Groups A, B, C, D locations, Enclosure Type 4X | 4-20 mA / DE | Vmax = 42.4V Imax = 225mA Ci = 4.2nF Li = * Pi = 1.2W | T4 Ta = 93°C |
| | | 4-20 mA / HART | Vmax = 30V Imax = 225mA Ci = 4.2nF Li = * Pi = 1.2W | T4 Ta = 93°C |
| | Nonincendive: Class I, Division 2, Groups A, B, C, D; Suitable for: Class II, Division 2, Groups F&G; Class III, Division 2; Class I, Zone 2, Group IIC, Enclosure Type 4X / IP 66/67 | Fieldbus – Entity (Not FNICO) | Vmax = 32V Imax = 120mA Ci = 4.2nF Li = 0 Pi = 0.84W | T4 Ta = 40°C T3 Ta = 93°C |
| | | Fieldbus – Entity (Not FNICO) | Vmax = 24V Imax = 250mA Ci = 4.2nF Li = 0 Pi = 1.2W | T4 Ta = 40°C T3 Ta = 93°C |
| | | FNICO | Vmax = 32V Ci = 4.2nF Li = 0 | T4 Ta = 40°C T3 Ta = 93°C |

* Li = 0 except Li = 150µH when Option ME, Analog Meter, is selected.

FM ApprovalsSM is a service mark of FM Global

| | Type of Protection | Comm. Option | Field Parameters | Temp. Codes | |
|---|--|--|---|------------------------------|--|
| Canadian Standards Association (CSA) | Explosion Proof: Class I, Division 1, Groups B, C, D locations Dust Ignition Proof: Class II, III, Division 1, Groups E, F, G locations, Enclosure Type 4X | All | All | T4 Ta = 93°C | |
| | Intrinsically Safe: Class I, II, III, Division 1, Groups A, B, C, D, E, F, G locations, Enclosure Type 4X | 4-20 mA / DE | Vmax = 42V Imax = 225mA Ci = 4.2nF Li = * Pi = 1.2W | T4 Ta = 93°C | |
| | | 4-20 mA / HART | Vmax = 42V Imax = 225mA Ci = 4.2nF Li = * Pi = 1.2W | T4 Ta = 93°C | |
| | | Fieldbus – Entity (Not FISCO) | Vmax = 24V Imax = 250mA Ci = 4.2nF Li = 0 Pi = 1.2W | T4 Ta = 40°C T3 Ta = 93°C | |
| | Nonincendive: Class I, Division 2, Groups A, B, C, D locations, Enclosure Type 4X | 4-20 mA / DE | Vmax = 42.4V Imax = 225mA Ci = 4.2nF Li = * Pi = 1.2W | T4 Ta = 93°C | |
| | | 4-20 mA / HART | Vmax = 30V Imax = 225mA Ci = 4.2nF Li = * Pi = 1.2W | T4 Ta = 93°C | |
| | | Fieldbus – Entity (Not FNICO) | Vmax = 24V Imax = 250mA Ci = 4.2nF Li = 0 Pi = 1.2W | T4 Ta = 40°C T3 Ta = 93°C | |
| | Canadian Registration Number (CRN): | All ST 3000 models except STG19L, STG99L, STG170 and STG180 have been registered in all provinces and territories in Canada and are marked CRN: 0F8914.5C. | | | |

| | Type of Protection | Comm. Option | Field Parameters | Temp. Codes |
|---|---|-------------------------|---|---|
| IECEX International Electrotechnical Commission (LCIE) | Flameproof, Zone 1: Ex d IIC, Enclosure IP 66/67 | All | All | T5 Ta = -50 to 93°C T6 Ta = -50 to 78°C |
| | Intrinsically Safe, Zone 0/1: Ex ia IIC, Enclosure IP 66/67 | 4-20 mA / DE | Ui = 30V li = 100mA Ci = 4.2nF Li = * Pi = 1.2W | T4 Ta = -50 to 93°C T5 Ta = -50 to 85°C T6 Ta = -50 to 70°C |
| | | 4-20 mA / HART | Ui = 30V li = 100mA Ci = 4.2nF Li = * Pi = 1.2W | T4 Ta = -50 to 93°C T5 Ta = -50 to 63°C T6 Ta = -50 to 48°C |
| | | Fieldbus (Not FISCO) | Ui = 24V li = 250mA Ci = 4.2nF Li = 0 Pi = 1.2W | T3 Ta = -50 to 93°C T4 Ta = -50 to 40°C |

* Li = 0 except Li = 150µH when Option ME, Analog Meter, is selected.

| | Type of Protection | Comm. Option | Field Parameters | Temp. Codes |
|--------------------------------|--|-------------------------|---|---|
| SAEx (South Africa) | Flameproof, Zone 1: Ex d IIC, Enclosure IP 66/67 | All | All | T5 Ta = -50 to 93°C T6 Ta = -50 to 78°C |
| | Intrinsically Safe, Zone 0/1: Ex ia IIC, Enclosure IP 66/67 | 4-20 mA / DE | Ui = 30V li = 100mA Ci = 4.2nF Li = * Pi = 1.2W | T4 Ta = -50 to 93°C T5 Ta = -50 to 85°C T6 Ta = -50 to 70°C |
| | | 4-20 mA / HART | Ui = 30V li = 100mA Ci = 4.2nF Li = * Pi = 1.2W | T4 Ta = -50 to 93°C T5 Ta = -50 to 63°C T6 Ta = -50 to 48°C |
| | | Fieldbus (Not FISCO) | Ui = 24V li = 250mA Ci = 4.2nF Li = 0 Pi = 1.2W | T3 Ta = -50 to 93°C T4 Ta = -50 to 40°C |
| | Multiple Marking: Flameproof, Zone 1: Ex d IIC, Enclosure IP 66/67 | 4-20 mA / DE | Ui = 30V li = 100mA Ci = 4.2nF Li = * Pi = 1.2W | T4 Ta = -50 to 93°C T5 Ta = -50 to 85°C T6 Ta = -50 to 70°C |
| | Intrinsically Safe, Zone 0/1: Ex ia IIC, Enclosure IP 66/67 | 4-20 mA / HART | Ui = 30V li = 100mA Ci = 4.2nF Li = * Pi = 1.2W | T4 Ta = -50 to 93°C T5 Ta = -50 to 63°C T6 Ta = -50 to 48°C |
| | NOTE: The user must determine the type of protection required for installation of the equipment. The user shall then check the box [√] adjacent to the type of protection used on the equipment certification nameplate. Once a type of protection has been checked on the nameplate, subsequently the equipment shall not be reinstalled using any of the other certification types. | Fieldbus (Not FISCO) | Ui = 24V li = 250mA Ci = 4.2nF Li = 0 Pi = 1.2W | T3 Ta = -50 to 93°C T4 Ta = -50 to 40°C |

* Li = 0 except Li = 150µH when Option ME, Analog Meter, is selected.

| | Type of Protection | Comm. Option | Field Parameters | Temp. Codes |
|----------------|--|-------------------------------|---|---|
| ATEX (LCIE) | Flameproof, Zone 0: ⊕ II 1 D, Ex tD Enclosure IP 66/67 | All | All | A20 IP6X T95°C Ta = 93°C or T80°C Ta = 78°C |
| | Flameproof, Zone 1: ⊕ II 2 GD, Ex d IIC, Ex tD Enclosure IP 66/67 | All | All | T5 Ta = -50 to +93°C T6 Ta = -50 to +78°C, A21 IP6X T95°C Ta = 93°C or T80°C Ta = 78°C |
| | Intrinsically Safe, Zone 0/1: ⊕ II 1 G, Ex ia IIC, Enclosure IP 66/67 | 4-20 mA / DE | U _i = 30V I _i = 100mA C _i = 4.2nF L _i = * P _i = 1.2W | T4 Ta = -50 to 93°C T5 Ta = -50 to 85°C T6 Ta = -50 to 70°C |
| | | 4-20 mA / HART | U _i = 30V I _i = 100mA C _i = 4.2nF L _i = * P _i = 1.2W | T4 Ta = -50 to 93°C T5 Ta = -50 to 63°C T6 Ta = -50 to 48°C |
| | | Fieldbus (Not FISCO) | U _i = 24V I _i = 250mA C _i = 4.2nF L _i = 0 P _i = 1.2W | T3 Ta = -50 to 93°C T4 Ta = -50 to 40°C |
| | Non-Sparking, Zone 2: ⊕ II 3 G, Ex nA IIC (Honeywell), Enclosure IP 66/67 | 4-20 mA / DE | U _i = 30V I _i = 100mA C _i = 4.2nF L _i = * P _i = 1.2W | T4 Ta = -50 to 93°C T5 Ta = -50 to 85°C T6 Ta = -50 to 70°C |
| | | 4-20 mA / HART | U _i = 30V I _i = 100mA C _i = 4.2nF L _i = * P _i = 1.2W | T4 Ta = -50 to 93°C T5 Ta = -50 to 63°C T6 Ta = -50 to 48°C |
| | | Fieldbus (Not FNICO) | U _i = 24V I _i = 250mA C _i = 4.2nF L _i = 0 P _i = 1.2W | T3 Ta = -50 to 93°C T4 Ta = -50 to 40°C |
| | Multiple Marking: Flameproof, Zone 1: ⊕ II 2 G, Ex d IIC Intrinsically Safe, Zone 0/1: ⊕ II 1 G, Ex ia IIC Non-Sparking, Zone 2: ⊕ II 3 G, Ex nA IIC NOTE: The user must determine the type of protection required for installation of the equipment. The user shall then check the box [√] adjacent to the type of protection used on the equipment certification nameplate. Once a type of protection has been checked on the nameplate, subsequently the equipment shall not be reinstalled using any of the other certification types. | 4-20 mA / DE | U _i = 30V I _i = 100mA C _i = 4.2nF L _i = * P _i = 1.2W | T4 Ta = -50 to 93°C T5 Ta = -50 to 85°C T6 Ta = -50 to 70°C |
| | | 4-20 mA / HART | U _i = 30V I _i = 100mA C _i = 4.2nF L _i = * P _i = 1.2W | T4 Ta = -50 to 93°C T5 Ta = -50 to 63°C T6 Ta = -50 to 48°C |
| | | Fieldbus (Not FISCO/FNICO) | U _i = 24V I _i = 250mA C _i = 4.2nF L _i = 0 P _i = 1.2W | T3 Ta = -50 to 93°C T4 Ta = -50 to 40°C |
| | | | | |

* L_i = 0 except L_i = 150µH when Option ME, Analog Meter, is selected.

| | Type of Protection | Comm. Option | Field Parameters | Temp. Codes |
|---|--|-------------------------|---|---|
| INMETRO (CERTUSP) Brazil | Flameproof, Zone 1: BR-Ex d IIC Enclosure IP 66/67 | All | All | T5 Ta = -50 to 93°C T6 Ta = -50 to 78°C |
| | Intrinsically Safe, Zone 0/1: BR-Ex ia IIC Enclosure IP 66/67 | 4-20 mA / DE | Ui = 30V li = 100mA Ci = 4.2nF Li = * Pi = 1.2W | T4 Ta = -50 to 93°C T5 Ta = -50 to 85°C T6 Ta = -50 to 70°C |
| | | 4-20 mA / HART | Ui = 30V li = 100mA Ci = 4.2nF Li = * Pi = 1.2W | T4 Ta = -50 to 93°C T5 Ta = -50 to 63°C T6 Ta = -50 to 48°C |
| | | Fieldbus (Not FISCO) | Ui = 24V li = 250mA Ci = 4.2nF Li = 0 Pi = 1.2W | T3 Ta = -50 to 93°C T4 Ta = -50 to 40°C |

* Li = 0 except Li = 150μH when Option ME, Analog Meter, is selected.

| | |
|--|---|
| ST 3000 Pressure Transmitter Marine Certificate (MT Option) | This certificate defines the certifications covered for the ST 3000 Pressure Transmitter family of products, including the SMV 3000 Smart Multivariable Transmitter. It represents the compilation of the five certificates Honeywell currently has covering the certification of these products into marine applications. For ST 3000 Smart Pressure Transmitter and SMV 3000 Smart Multivariable Transmitter |
| | American Bureau of Shipping (ABS) - 2009 Steel Vessel Rules 1-1-4/3.7, 4-6-2/5.15, 4-8-3/13 & 13.5, 4-8-4/27.5.1, 4-9-7/13. Certificate number: 04-HS417416-PDA |
| | Bureau Veritas (BV) - Product Code: 389:1H. Certificate number: 12660/B0 BV |
| | Det Norske Veritas (DNV) - Location Classes: Temperature D, Humidity B, Vibration A, EMC B, Enclosure C. For salt spray exposure; enclosure of 316 SST or 2-part epoxy protection with 316 SST bolts to be applied. Certificate number: A-11476 |
| | Korean Register of Shipping (KR) - Certificate number: LOX17743-AE001 |
| | Lloyd's Register (LR) - Certificate number: 02/60001(E1) & (E2) |

| | |
|--|--|
| <p>European Pressure Equipment Directive (PED) (97/23/EC)</p> | <p>The ST 3000 Smart Pressure Transmitters are in conformity with the essential requirements of the Pressure Equipment Directive.</p> <p>Honeywell ST 3000 Smart Pressure Transmitters are designed and manufactured in accordance with the applicable portions of Annex I, Essential Safety Requirements, and sound engineering practices. These transmitters have no pressurized internal volume, or have a pressurized internal volume rated less than 200 bar (2,900 psig), and/or have a maximum volume of less than 0.1 liter (Article 3, 1.1.(a) first indent, Group 1 fluids). Therefore, these transmitters are not subject to the essential requirements of the directive 97/23/EC (PED, Annex I) and shall not have the CE mark applied.</p> <p>For transmitters rated > 200 bar (2,900 psig) < 1,000 bar (14,500 psig) Honeywell maintains a technical file in accordance with Annex III, Module A, (internal production control) when the CE mark is required. Transmitter Attachments: Diaphragm Seals, Process Flanges and Manifolds comply with Sound Engineering Practice.</p> <p>NOTE: Pressure transmitters that are part of safety equipment for the protection of piping (systems) or vessel(s) from exceeding allowable pressure limits, (equipment with safety functions in accordance with Pressure Equipment Directive 97/23/EC article 1, 2.1.3), require separate examination.</p> <p>A formal statement from TÜV Industry Service Group of TÜV America, Inc., a division of TÜV Süddeutschland, a Notified Body regarding the Pressure Equipment Directive, can be found at www.honeywell.com. A hard copy may be obtained by contacting a Honeywell representative.</p> |
| <p>CE Mark</p> | <p><i>Electro Magnetic Compatibility (EMC) (2004/108/EC)</i> All Models: EN 50081-1: 1992; EN 50082-2:1995; EN 61326-1:1997 + A1, A2, and A3 – Industrial Locations</p> |
| <p>Dual Seal Certification</p> | <p>Dual Seal Certification based on ANSI/NFPA 70-202 and ANSI/ISA 12.27.01 requirements without the use of additional seal protection elements.</p> |
| <p>Recommended Frequency of Calibration</p> | <p>Honeywell recommends verifying the calibration of these devices once every four years.</p> |
| <p>Approved Manufacturing Locations</p> | <p>Honeywell Process Solutions - York, PA USA Honeywell (Tianjin) Limited – Tianjin, P.R. China Honeywell Automation India Ltd. – Pune 411013 India</p> |

Foundation™ Fieldbus is a trademark of the Fieldbus Foundation.

HART® is a registered trademark of HART Communications Foundation.

Hastelloy® C-276 is a registered trademark of Haynes International.

Monel® 400 is a registered trademark of Special Metals Corporation.

ST 3000® and Experion® are registered trademarks of Honeywell International Inc.

Neobee® M-20 is a registered trademark of Stephan Company.

Viton® is a registered trademark of DuPont.

Teflon® is a registered trademark of DuPont.

DC® 200 is a registered trademark of Dow Corning.

FM ApprovalsSM is a service mark of FM Global.

Mounting

Reference Dimensions: $\frac{\text{millimeters}}{\text{inches}}$

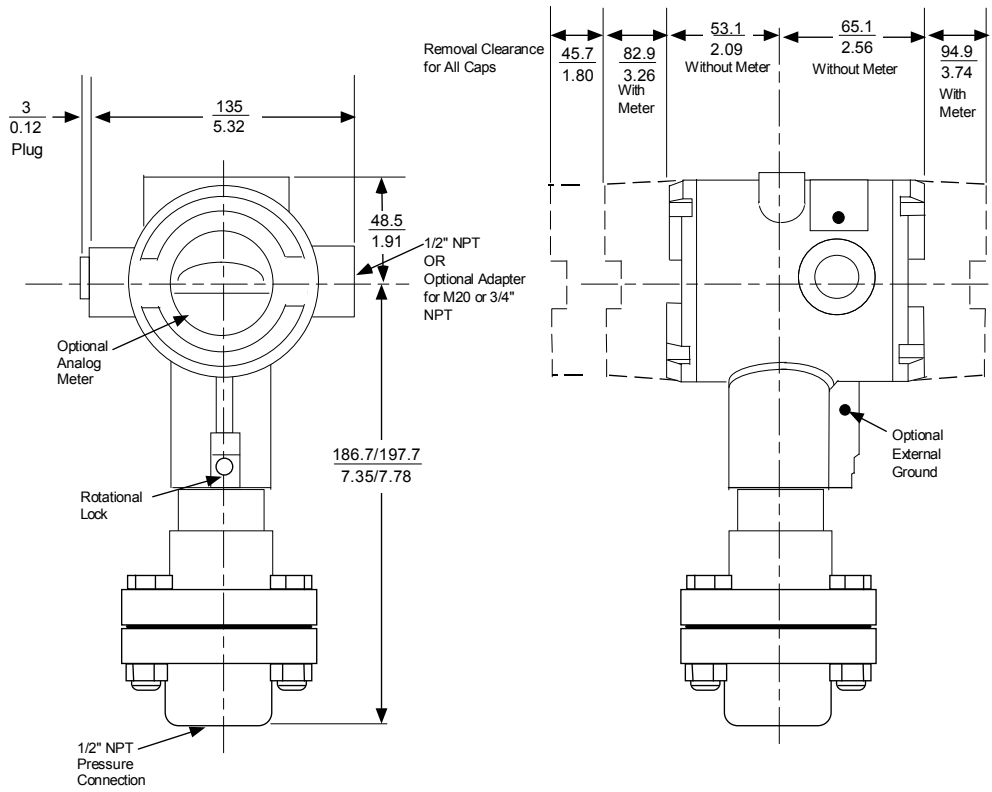
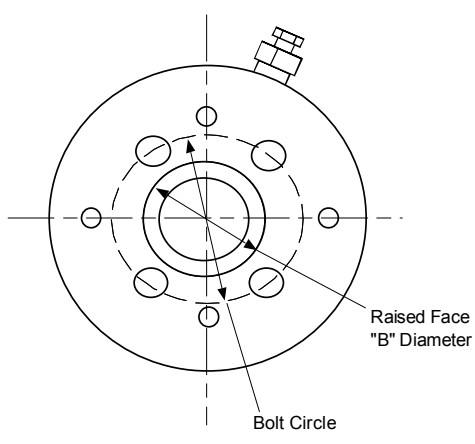
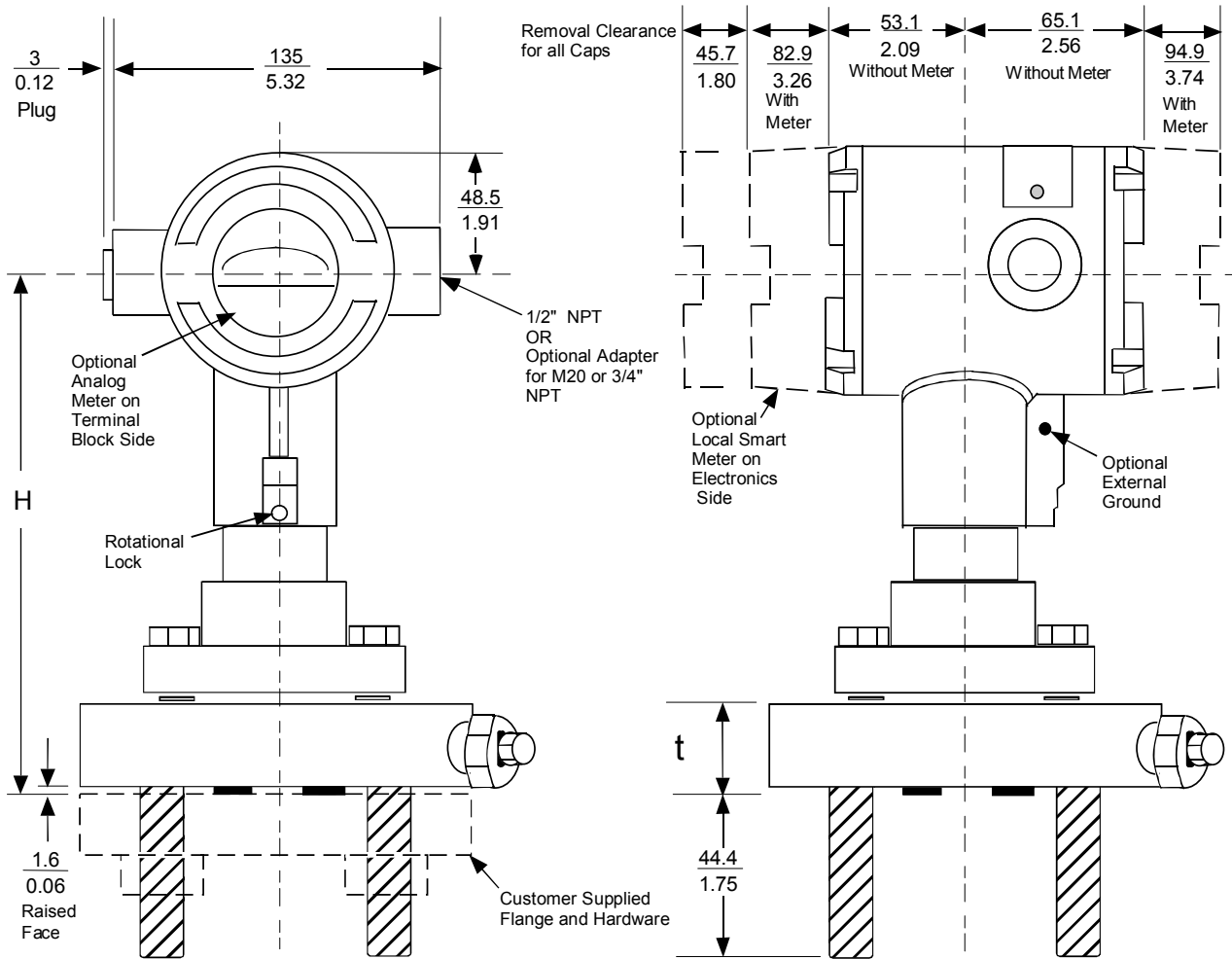

Figure 4—Typical mounting dimensions for 1/2-inch NPT connection models for reference.

Reference Dimensions: $\frac{\text{millimeters}}{\text{inches}}$



| Flange Description | | Flange Thickness (t) | Height "H" | Flange Dia. | Stud Size * | Hole Dia. | Bolt Circle | Raised Face "B" Dia. |
|--------------------|--------|----------------------|---------------|---------------|-------------|------------|---------------|----------------------|
| 150 lb | 1/2" | 26.6 1.05 | 187.1 7.37 | 88.9 3.5 | 1/2-13 | | 60.3 2.38 | 34.9 1.38 |
| | 1" | | | 108.0 4.25 | 1/2-13 | | 79.4 3.12 | 50.8 2.00 |
| | 1-1/2" | | | 127.0 5.00 | 1/2-13 | | 98.4 3.88 | 73.0 2.88 |
| | 2" | | | 154.4 6.00 | | 19 0.75 | 120.7 4.75 | 92.0 3.62 |
| 300 lb | 1" | 28.6 1.13 | 189.2 7.45 | 124.0 4.88 | 5/8-11 | | 88.9 3.50 | 50.8 2.00 |
| | 1-1/2" | | | 155.5 6.12 | 3/4-10 | | 114.3 4.50 | 73.0 2.88 |
| | 2" | | | 165.1 6.50 | | 19 0.75 | 127.0 5.00 | 92.0 3.62 |

* Studs are threaded and welded in place.

Figure 5—Typical mounting dimensions for small flange connection models for reference.

Options

- **Indicating Meter (Options ME and SM)**

Two integral meter options are available. An analog meter (option ME) is available with a 0 to 100% linear scale. The Smart Meter (option SM) provides an LCD display for both analog and digital output and can be configured to display pressure in pre-selected engineering units.

- **Lightning Protection (Option LP)**

A terminal block is available with circuitry that protects the transmitter from transient surges induced by nearby lightning strikes.

- **HART® Protocol Compatibility (Options HC and H6)**

Optional electronics modules for the ST 3000 provide HART Protocol compatibility in either HART 5.x or 6.x formats. Transmitters with a HART Option are compatible with any HART enabled system that provides 5.x or 6.x format support.

- **Foundation™ Fieldbus (Option FF)**

Equips transmitter with FF protocol for use in 31.25 kbit/s FF networks. See document 34-ST-03-72 for additional information on ST 3000 Fieldbus transmitters.

- **SIL2/SIL3 Certification (Option SL)**

This ST 3000 product is available for use with safety systems. With the SL option, we are fully certified to SIL 2 capability for single transmitters and SIL 3 capability for multiple transmitter use through TÜV Nord Sys Tec GmbH & Co. KG. We are in compliance with the following SIL standards:

IEC 61508-1: 1998

IEC 61508-2: 2000

IEC 61508-3: 1998

- **NAMUR NE43 Compliance (Option NE)**

This option provides software that meets the NAMUR NE43 requirements for failsafe software. Transmitter failure information is generated when the measuring information is no longer valid.

Transmitter failure values are: ≤ 3.6 mA and ≥ 21.0 mA.

The normal ST 3000 ranges are ≤ 3.8 mA and ≥ 20.5 mA.

- **Transmitter Configuration (Options TC and FC)**

With Option TC, the factory can configure the analog, DE or HART® transmitter's linear/square root extraction, damping time, LRV, URV and mode (analog/digital) and enter an ID tag of up to eight characters and scratchpad information as specified.

With Option FC, the Device ID, Transmitter Tag, Unit Level Node Address, Output Mode and Damping Time Constants can be specified.

- **Lifetime Warranty (Option WL)**

Extends limited 1-year warranty policy to 15 years for ST 3000 S100 pressure transmitters. See Honeywell Terms and Conditions.

- **Indicator Configuration (Option CI)**

Provides custom configuration of Smart Meters.

- **Tagging (Option TG)**

Up to 30 characters can be added on the stainless steel nameplate mounted on the transmitter's electronics housing at no extra cost. Note that a separate nameplate on the meter body contains the serial number and body-related data. A stainless steel wired on tag with additional data of up to 4 lines of 28 characters is also available. The number of characters for tagging includes spaces.

- **Custom Calibration and ID in Memory (Option CC)**

The factory can calibrate any range within the scope of the transmitter's range and enter an ID tag of up to eight characters in the transmitter's memory.

Ordering information

For application assistance, current specifications, pricing, or name of the nearest Authorized Distributor, contact one of the offices below. Or, visit Honeywell on the World Wide Web at: <http://www.honeywell.com>.

ASIA PACIFIC

Control Products

Asia Pacific Headquarters
Phone: +(65) 6355-2828
Fax: +(65) 6445-3033

Asia Pacific Global Technical Support

Field Instruments
Phone: +65 6580 3156
Fax: +65 6445-3033

Process Instruments

Phone: (603) 76950 4777
Fax: (603) 7958 8922

Australia

Honeywell Limited
Phone: +(61) 7-3846 1255
FAX: +(61) 7-3840 6481
Toll Free 1300-36-39-36
Toll Free Fax:
1300-36-04-70

China – PRC - Beijing

Honeywell China Inc.
Phone: +(86-10) 8458-3280
Fax: +(86-10) 8458-4650

China – PRC - Shanghai

Honeywell China Inc.
Phone: (86-21) 5257-4568
Fax: (86-21) 6237-2826

China – PRC - Chengdu

Honeywell China Inc.
Phone: +(86-28) 8678-6348
Fax: +(86-28) 8678-7061

China – PRC - Xi'an

Honeywell China Ltd - Xi'an.
Phone: +(86-29) 8833-7490
Fax: +(86-29) 8833-7489

China – PRC - Shenzhen

Honeywell China Inc.
Phone: +(86) 755-2518-1226
Fax: +(86) 755-2518-1221

Indonesia

PT Honeywell Indonesia
Phone: +(62) 21-535-8833
FAX: +(62) 21-5367 1008

India

Automation India Ltd.
Honeywell Ltd.
Phone: +(91) 5603-9400
Fax: +(91) 5603-9600

Japan

Honeywell Inc.
Phone: +(81) 3 6730 7150
Fax: +(81) 3 6730 7228

Malaysia

Honeywell Engineering
Sdn Bhd
Phone: +(60-3) 7950-4776
Fax: +(60-3) 7958-8922

New Zealand

Honeywell Limited
Phone: +(64-9) 623-5052
Fax: +(64-9) 623-5060
Toll Free (0800) 202-088

Philippines

Honeywell Systems
(Philippines) Inc.
Phone: +(63-2) 633-2830-31/
636 1661-62
Fax: +(63-2) 638-4013

Singapore

Honeywell Pte Ltd.
Phone: +(65) 6580 3278
Fax: +(65) 6445-3033

South Korea

Honeywell Korea Co Ltd
Phone: +(822) 799 6315
Fax: +(822) 792 9015

Thailand

Honeywell Systems
(Thailand) Ltd.
Phone: +(662) 693-3099
FAX: +(662) 693-3089

Taiwan R.O.C.

Honeywell Taiwan Ltd.
Phone: +(886-2) 2245-1000
FAX: +(886-2) 2245-3241

SE Asia Countries

see Honeywell Pte Ltd
(Singapore)
for:

Pakistan
Cambodia
Guam
Laos
Myanmar
Vietnam
East Timor

SE Asia Countries

see Honeywell Automation
India Ltd for:
Bangladesh
Nepal
Sri Lanka

EUROPE

Austria

Honeywell Austria GmbH
Phone: +43 (316)400123
FAX: +43 (316)40017

Belgium

Honeywell SA/NV
Phone: +32 (0) 2 728 24 07
FAX: +32 (0) 2 728 22 45

Bulgaria

Honeywell EOOD
Phone: +(359) 2 40 20 900
FAX: +(359) 2 40 20 990

Czech Republic

Honeywell spol. s.r.o.
Phone: +420 242 442 232
FAX: +420 242 442 131

Denmark

Honeywell A/S
Phone: +(45) 39 55 55 55
FAX: +(45) 39 55 55 58

Finland

Honeywell OY
Phone: +358 (0) 20752 2753
FAX: +358 (0) 20752 2751

France

Honeywell SA
Phone: +33 (0)1 60198075
FAX: +33 (0)1 60198201

Germany

Honeywell AG
Phone: +49 (69)8064-299
FAX: +49 (69)806497336

Hungary

Honeywell Kft.
Phone: +36-1-451 4300
FAX: +36-1-451 4343

Italy

Honeywell S.p.A.
Phone: +39 02 92146 307/
395
FAX: +39 0292146377

The Netherlands

Honeywell B.V.
Phone: +31 (0) 20 5656200
FAX: +31 (0) 20 5656210

Norway

Honeywell A/S
Phone: (45) 39 55 55 55

Poland

Honeywell Sp. zo.o
Phone: +48-22-6060900
FAX: +48-22-6060901

Portugal

Honeywell Portugal Lda
Phone: +351 21 424 5000
FAX: +351 21 424 50 99

Romania

Honeywell Bucharest
Phone: +40 (0) 21 2316437
FAX: +40 (0) 21 2316439

Russian Federation (RF),

ZAO "Honeywell"
Phone: +7 (095) 796 98 00
FAX: +7 (495) 797 99 64

Slovak Republic

Honeywell s.r.o.
Phone: +421-2-58247 410
FAX: +421-2-58247 415

Spain

Honeywell S.A.
Phone: +34 (0)91313 61 00
FAX: +34 (0)91313 61 30

Sweden

Honeywell AB
Phone: +(46) 8 775 55 00
FAX: +(46) 8 775 56 00

Switzerland

Honeywell AG
Phone: +41 18552448
FAX: +(41) 1 855 24 45

Turkey

Honeywell Turkey A.S.
Phone: +90 216 578 71 00
FAX: +90 216 575 66 35

Ukraine

Honeywell
Tel: +380-44-201 44 74
Fax: +380-44-201-44-75

United Kingdom

Honeywell Control Systems
Ltd.
Phone: +44 (0)1344 655251
FAX: +44 (0) 1344 655554

MIDDLE EAST

Abu Dhabi U A E

Middle East Headquarters
Honeywell Middle East Ltd.
Phone: +971 2 4041246
FAX: +971 2 4432536

Sultanate of Oman

Honeywell & Co Oman LLC
Phone: +968 24 701153/
Ext.33
FAX: +968 24 787351

Saudi Arabia

Honeywell Turki Arabia Ltd
Jubail Office
Phone: +966-3-341-0140
Fax: +966-3-341-0216
Honeywell - ATCO
Dammam Office
Phone: 0096638304584
Fax: 0096638338059

Kuwait

Honeywell Kuwait KSC
Phone: +965 242 1327 to 30
Fax: +965 242 8315
and
Phone: +965 326 2934/1821
Fax: +965 326 1714

AFRICA

Mediterranean & African Distributors

Honeywell SpA
Phone: +39 (02) 250 10 604
FAX: +39 (02) 250 10 659

South Africa (Republic of) and sub saharan

Honeywell Southern Africa
Honeywell S.A. Pty. Ltd.
Phone: +27 11 6958000
FAX +27 118051504

NORTH AMERICA

Canada

Honeywell LTD
Phone: 1-800-737-3360
FAX: 1-800-565-4130

USA

Honeywell Process Solutions,
Phone: 1-800-423-9883
Or 1-800-343-0228
Email: ask-ssc@honeywell.com

SOUTH AMERICA

Argentina

Honeywell S.A.I.C.
Phone: +(54-11) 4383-3637
FAX: +(54-11) 4325-6470

Brazil

Honeywell do Brasil & Cia
Phone: +(55-11) 7266-1900
FAX: +(55-11) 7266-1905

Chile

Honeywell Chile, S.A.
Phone: +(56-2) 233-0688
FAX: +(56-2) 231-6679

Mexico

Honeywell S.A. de C.V.
Phone: +(52) 55 5259-1966
FAX: +(52) 55 5570-2985

Puerto Rico

Honeywell Inc.
Phone: +(809) 792-7075
FAX: +(809) 792-0053

Trinidad

Honeywell Inc.
Phone: +(868) 624-3964
FAX: +(868) 624-3969

Venezuela

Honeywell CA
Phone: +(58-2) 238-0211
FAX: +(58-2) 238-3391

Specifications are subject to change without notice.

Model Selection Guides are subject to change and are inserted into the specifications as guidance only. Prior to specifying or ordering a model check for the latest revision Model Selection Guides which are published at: <http://hpsweb.honeywell.com/Cultures/en-US/Products/Instrumentation/ProductModelSelectionGuides/default.htm>

Model Selection Guide (34-ST-03-47)



34-ST-16U-47
Issue 32
Page 1 of 4

ST 3000 Smart Transmitter High Temperature Models Series 100

Model Selection Guide



Instructions

- Select the desired Key Number. The arrow to the right marks the selection available.
- Make one selection from each Table I and II using the column below the proper arrow.
- Select as many Table III options as desired (if no options or approvals are desired, specify 0X).
- An approval code MUST be selected.
- A (●) denotes unrestricted availability. A letter denotes restricted availability.
- Restrictions follow Table IV.

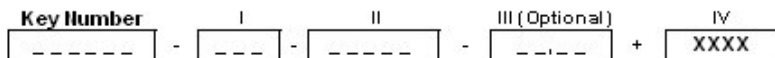

KEY NUMBER

| Span | Selection | Avail. |
|---|-----------|--------|
| 0-0.9 to 0-500 psig/0-0.063 to 0-35 barg | STG14T | ↓ |
| 0-0.9 to 0-500 psig/0-0.063 to 0-35 barg - Flange Mount | STF14T | ↓ |

(The STG 14T & STF14T replace the STG & STF 15T models)

Base STF and STF models no longer include a default communications option. All units now require the selection of a communication option from Table III (AN, DE, HC, H6 or FF).

Important Note:

TABLE I - METER BODY

| | Barrier Diaphragm | Process Heads (wetted) | Selection | | |
|--------------------------------|------------------------------|--------------------------|-----------------------|-----|-----|
| Materials | Tri-clamp™ | 316L SS | - | Z__ | ● |
| | Threaded | 316L SS | 316 SS ¹ | E__ | ● |
| | | Barrier Diaphragm | Lower (wetted) | | |
| | Flange | 316L SS | 316 SS ¹ | E__ | ● |
| Fill Fluid | DC [®] 200 Silicone | | | _1_ | ● ● |
| | Neobee [®] | | | _4_ | ● ● |
| Process Head Connection | No Selection | | | _0 | ● ● |
| | 1/2" NPT (female) | | | _G | f |

TABLE II - FLANGE ASSEMBLY

| | | Selection | | |
|---------------------|-----------------------|--------------|-------|---|
| No Selection | No Selection | 0_____ | ● | ● |
| Flange | No Selection | _0_____ | ● | ● |
| | 1/2" ANSI Class 150 | _G_____ | ● | ● |
| | 1" ANSI Class 150 | _Q_____ | ● | ● |
| | 1" ANSI Class 300 | _V_____ | ● | ● |
| | 1 1/2" ANSI Class 150 | _W_____ | ● | ● |
| | 1 1/2" ANSI Class 300 | _X_____ | ● | ● |
| | 2" ANSI Class 150 | _Y_____ | ● | ● |
| | 2" ANSI Class 300 | _Z_____ | ● | ● |
| | No Selection | No Selection | __0__ | ● |
| No Selection | No Selection | ___0_ | ● | ● |
| Vent/Drain | No Selection | ____0 | ● | ● |
| | 316 SS ¹ | ____1 | ● | ● |

¹ Supplied as 316 SS or as Grade CF8M, the casting equivalent of 316 SS.

34-ST-16U-47
 Issue 31
 Page 2 of 4

TABLE III - OPTIONS

| | STG14T Selection | Availability | | STF14T |
|---|------------------|--------------|----|--------|
| | | ↓ | ↓ | |
| Communication Options <i>(Must choose a communications option)</i> | | | | |
| Analog only (can be configured using appropriate Honeywell DE tool) | AN | • | • | b |
| DE Protocol communications | DE | • | • | |
| HART® 5.x Protocol Compatible Electronics | HC | • | • | |
| HART® 6.x Protocol Compatible Electronics | H6 | • | • | |
| FOUNDATION™ Fieldbus Communications | FF | r | r | |
| Indicating Meter Options | | | | |
| Analog Meter (0-100 Even 0-10) | ME | • | • | b |
| Smart Meter | SM | • | • | |
| Custom Configuration of Smart Meter | CI | e | e | b |
| Local Zero | LZ | x | x | |
| Local Zero and Span | ZS | m | m | |
| Transmitter Housing & Electronics Options | | | | |
| NAMUR Failsafe Software | NE | 15 | 15 | b |
| SIL 2 - TÜV Certified transmitter (requires HC or H6 and WP options) | SL | p | p | |
| Lightning Protection | LP | • | • | |
| Custom Calibration and I.D. in Memory | CC | • | • | |
| Transmitter Configuration (non-Fieldbus) | TC | 15 | 15 | |
| Transmitter Configuration (Fieldbus) | FC | 21 | 21 | |
| Write Protection (Delivered in the "enabled" position) | WP | • | • | |
| Write Protection (Delivered in the "disabled" position) | WX | • | • | |
| 316 SS ¹ Electronics Housing - <i>(with M20 Conduit Connections)</i> | SH | n | n | |
| M20 316 SS Conduit Adapter | A1 | n | n | |
| 3/4" NPT 316 SS Conduit Adapter | A2 | • | • | |
| 316 SS ¹ Housing with M20 to 1/2" NPT 316 SS Conduit Adapter <i>(use for FM and CSA Approvals)</i> | A3 | i | i | |
| Stainless Steel Customer Wired-on Tag <i>(4 lines, 28 characters per line, customer supplies information)</i> | TG | • | • | |
| Stainless Steel Customer Tag (blank) | TB | • | • | |
| End Cap Live Circuit Warning Label in Spanish (only with ATEX 3D) | SP | a | a | |
| End Cap Live Circuit Warning Label in Portuguese (only with ATEX 3D) | PG | a | a | |
| End Cap Live Circuit Warning Label in Italian (only with ATEX 3D) | TL | a | a | |
| End Cap Live Circuit Warning Label in German (only with ATEX 3D) | GE | a | a | |
| Meter Body Options | | | | |
| Viton® Process Head Gasket (teflon is standard) | VT | d | • | b |
| A286 SS NACE Bolts (and on STG14T 304 SS NACE Nuts also) | CR | d | • | |
| Services/Certificates/Marine Type Approval Options | | | | |
| User's Manual Paper Copy (Standard, HC, H6 or FF ships accordingly) | UM | • | • | b |
| Calibration Test Report & Certificate of Conformance (F3399) | F1 | • | • | |
| Certificate of Conformance (F3391) | F3 | • | • | |
| Certificate of Origin (F0195) | F5 | • | • | |
| FMEDA Certificate (SIL 1) (FC33321) | F6 | • | • | |
| SIL Certificate (SIL 2/3) (FC33337) | FE | 22 | 22 | |
| NACE Certificate (Process-Wetted & Non-Process Wetted) (FC33339) | F7 | o | o | |
| NACE Certificate (Process-Wetted only) (FC33338) | FG | • | • | |
| Material Traceability Certification per EN 10204 3.1 (FC33341) | FX | • | • | |
| Marine Type Approvals (DNV, ABS, BV, KR & LR) (FC33340) | MT | • | • | |
| Warranty Options | | | | |
| Additional Warranty - 1 year | W1 | • | • | b |
| Additional Warranty - 2 years | W2 | • | • | |
| Additional Warranty - 3 years | W3 | • | • | |
| Additional Warranty - 4 years | W4 | • | • | |
| Lifetime Warranty - 15 years | WL | • | • | |

Table III continued next page

¹ Supplied as 316 SS or as Grade CF8M, the casting equivalent of 316 SS.

TABLE III - OPTIONS (continued)

| Approval Body | Approval Type | Location or Classification | Selection | Availability | |
|--------------------------------------|---|--|-----------|--------------|--------|
| | | | | STG14T | STF14T |
| No hazardous location approvals | | | 9X | • | • |
| FM Approvals SM | Explosion Proof | Class I, Div. 1, Groups A,B,C,D | 1C | • | • |
| | Dust Ignition Proof | Class II, III, Div. 1, Groups E,F,G | | | |
| | Non-Incendive | Class I, II, III, Div. 2, Groups A,B,C,D,F,G | | | |
| | Intrinsically Safe Explosion Proof | Class I, II, III, Div. 1, Groups A,B,C,D,E,F,G Class I, Div. 1, Groups B,C,D | | | |
| Canadian Standards Association (CSA) | Dust Ignition Proof | Class II, III, Div. 1 Groups E,F,G | 2J | • | • |
| | Intrinsically Safe | Class I, II, III, Div. 1, Groups A,B,C,D,E,F,G | | | |
| | Suitable for use in | Class I, II, III, Div. 2, Groups A,B,C,D,E,F,G | | | |
| IECEX | Flameproof, Zone 1 | Ex d IIC; T5 (Ta = -40 to +93°C), T6 (Ta = -40 to +78°C) | CA | • | • |
| | Intrinsically Safe, Zone 0/1 | Ex ia IIC; T3, T4, T5, T6 See Spec for detailed temperature codes by Communications option | | | |
| ATEX ¹⁰ (LCIE) | Intrinsically Safe Zone 0 | Ex ia IIC T4 (Ta = -50°C to +93°C); T5 (Ta = -50°C to +85°C); T6 (Ta = -50°C to +70°C) Enclosure IP 66/67 | 3S | 23 | 23 |
| | Intrinsically Safe | Ex ia IIC T4 (Ta = -50°C to +93°C); T5 (Ta = -50°C to +85°C); T6 (Ta = -50°C to +70°C) Enclosure IP 66/67 | | | |
| | Dust-Ignitionproof, Zone 0 | Ex tD A20 IP6X T95°C (at Ta = 93°C) or T80°C (at Ta = 78°C) Enclosure IP 66/67 | 33 | • | • |
| | Flameproof, Zone 1 | Ex d IIC T5 (Ta = -40°C to +93°C), T6 (Ta = -40°C to +78°C) Supply 11- 42Vdc Ex tD A21 IP6X T95°C (at Ta = 93°C) or T80°C (at Ta = 78°C) Enclosure IP 66/67 | | | |
| | Multiple Marking ¹¹ Int. Safe, Zone 0/1, or Flameproof, Zone 1, or Non-Sparking, Zone 2 | Ex ia IIC T4 (Ta = -50°C to +93°C); T5 (Ta = -50°C to +85°C); T6 (Ta = -50°C to +70°C); Ui = 30V; li = 100mA Ex tD A20 IP6X T95°C (at Ta = 93°C) or T80°C (at Ta = 78°C) | | | |
| | | Ex d IIC T5 (Ta = -40°C to +93°C), T6 (Ta = -40°C to +78°C) Supply 11- 42Vdc Ex tD A21 IP6X T95°C (at Ta = 93°C) or T80°C (at Ta = 78°C) | 3C | • | • |
| | | Ex nA, IIC T5 (Ta = -40°C to +93°C), T6 (Ta = -40°C to +78°C); Zone 2 Supply < 42Vdc, 23mA Ex tD A22 IP6X T95°C (at Ta = 93°C) or T80°C (at Ta = 78°C) (Honeywell) Enclosure IP 66/67 | | | |

Table III Approvals continued next page

34-ST-16U-47

Issue 31

Page 4 of 4

TABLE III - Approval Options (continued)

| Approval Body | Approval Type | Location or Classification | Selection | Availability | |
|--------------------------------|---|---|-----------|--------------|--------|
| | | | | STG14T | STF14T |
| SAEx (South Africa) | Intrinsically Safe, Zone 0/1 | Ex ia IIC T4, T5, T6 | Z2 | • | • |
| | Flameproof, Zone 1 | Ex d IIC T5, T6 Enclosure IP 66/67 | ZD | • | • |
| | Multiple Marking ¹¹ Int. Safe, Zone 0/1, or Flameproof, Zone 1 | Ex ia IIC T4, T5, T6 Ex d IIC T5, T6 Enclosure IP 66/67 | ZA | • | • |
| CERTUSP INMETRO (Brazil) | Flameproof, Zone 1 | BR- Ex d IIC T5, T6 | 6D | • | • |
| | Intrinsically Safe, Zone 0/1 | BR- Ex ia IIC ; T4, T5, T6 (See CERTUSP certificate for detailed temperature codes by Communications option) | 6S | • | • |

¹⁰ See ATEX installation requirements in the ST 3000 User's Manual

¹¹ The user must determine the type of protection required for installation of the equipment. The user shall then check the box [✓] adjacent to the type of protection used on the equipment certification nameplate. Once a type of protection has been checked on the nameplate, subsequently the equipment shall not be reinstalled using any of the other certification types.

TABLE IV

| | | | |
|------------------------|------|---|---|
| Factory Identification | XXXX | • | • |
|------------------------|------|---|---|

RESTRICTIONS

| Restriction Letter | Available Only With | | Not Available With | |
|--------------------|---------------------|---|--------------------|----------------|
| | Table | Selection | Table | Selection |
| a | III | 33 or 3C | | |
| b | III | Select only one option from this group. | | |
| d | I | E | | |
| e | III | SM | | |
| f | | | I | Z |
| i | III | 1C or 2J | | |
| m | | | III | FF, ME |
| n | | | III | 1C, 2J |
| o | III | CR | | |
| p | III | HC or H6 and WP | III | FF, 00 |
| r | | | III | TC, ME, CA, 3S |
| w | I | | | |
| x | III | FF, SM | | |
| 15 | | | III | FF |
| 21 | III | FF | | |
| 22 | | SL | | |
| 23 | III | SH or A3 | | |

Ordering Example: STG14T-Z10-00000-HC,LP,2J+XXXX

HART® is a registered trademark of HART Communication Foundation.

FOUNDATION™ Fieldbus is a trademark of Fieldbus Foundation.

Neobee® is a registered trademark of Stepan Company.

Viton® is a registered trademark of DuPont Performance Elastomers.

FM ApprovalsSM is a service mark of FM Global

DC® 200 is a registered trademark of Dow Corning

This page has been intentionally left blank

For More Information

Learn more about how ST 3000 S100 Transmitters can increase performance, reduce downtime and decrease configuration costs, visit our website www.honeywell.com/ps or contact your Honeywell account manager.

Honeywell Process Solutions

1860 West Rose Garden Lane
Phoenix, Arizona 85027
Tel: 1-800-423-9883 or 1-800-343-0228
<http://www.honeywell.com/ps/hfs>

34-ST-03-70
April 2011
© 2011 Honeywell International Inc.

Honeywell