

ST 3000 Smart Pressure Transmitter Series 100 Absolute Pressure Models Specifications

34-ST-03-61 June 2011



Introduction

In 1983, Honeywell introduced the first Smart Pressure Transmitter—the ST 3000®. In 1989, Honeywell launched the first all digital, bi-directional protocol for smart field devices. Today, its ST 3000 Series 100 Absolute Pressure Transmitters continue to bring proven “smart” technology to a wide spectrum of measurement applications. Honeywell In-line (STA12L, STA14L and STA17L) and single head (STA122 and STA140) absolute pressure transmitters are used in applications in which high accuracy in the vacuum range of pressure is needed to include low-pressure measurement in vacuum distillation columns, where energy savings are directly proportional to the vacuum in the column. Honeywell transmitters can be used in a wide spectrum of hazardous environments in perfect safety to provide proven, repeatable pressure measurements.



Figure 1 -
On the right is Model STA122 and STA140 and on the left are Models STA12L, STA14L and STA17L. All Series 100 Absolute Pressure Transmitters feature field-proven piezoresistive sensor technology

Models		
STA122 / STA12L	0 to 780 mHgA	0 to 1,040 mbarA
STA140 / STA14L	0 to 500 psia	0 to 35 barA
STA17L	0 to 3,000 psia	0 to 206.8 bar A

All ST 3000 transmitters can be ordered to provide one of the following output communication options.

Communications options
4-20 mA
Honeywell Digitally Enhanced (DE)
HART® (versions 5.x or 6.x)
FOUNDATION™ Fieldbus

When digitally integrated with Honeywell’s Experion® Process Knowledge System or other TDC/TPS systems, ST 3000 instruments provides local measurement accuracy to the system level without adding typical A/D and D/A converter inaccuracies as well as providing advantages from the many other on-board advanced diagnostic features.

Honeywell’s high-performance ST 3000 S100 transmitters lead the industry in:

- Accuracy
- Reliability
- Rangeability
- Warranty

ST 3000 Lifetime™ Transmitter Benefits
Total Accuracy = ±0.0375%
Reliability = 470 years MTBF
Rangeability = up to 400 to 1
Lifetime Warranty = 15 years

The devices provide comprehensive self-diagnostics to help users maintain high uptime, meet regulatory requirements, and attain high quality standards. S100 transmitters are ideal for critical applications, such as custody transfer of natural gas and energy and material balances, where accuracy and stability are important.

Description

The ST 3000 transmitter can replace any 4 to 20 mA output transmitter in use today and operates over a standard two-wire system.

The measuring means is a piezoresistive sensor, which actually contains three sensors in one. It uses a differential pressure sensor, a temperature sensor and a static pressure sensor in delivering the most comprehensive compensated output signal available today.

Microprocessor-based electronics provide higher span-turndown ratio, improved temperature and pressure compensation, and improved accuracy.

The transmitter's meter body and electronics housing resist shock, vibration, corrosion, and moisture. The electronics housing contains a compartment for the single-board electronics, which is isolated from an integral junction box. The single-board electronics is replaceable and interchangeable with any other ST 3000 Series 100 or Series 900 model transmitters.

Advanced Diagnostics

ST 3000 is now available for both HART[®] 6 and Foundation[™] Fieldbus with advanced diagnostics that minimize unplanned plant outages, minimize maintenance costs and by providing the industry's most reliable transmitter.

- Provide advanced warning of possible failure events and avoid costly shutdowns.
- Three levels of failure reporting
- Comprehensive list of on-board diagnostics (Ref. ST 3000 User manual with HART[®] 6, 34-ST-25-17 Rev: June 09 and Foundation[™] Fieldbus option manual 34-ST-25-15 Rev: June 09)

Configuration Tools

Like other Honeywell transmitters, the ST 3000 features two-way communication and configuration capability between the operator and the transmitter through several Honeywell field-rated portable configuration devices, including the Smart Field Communicator (SFC) and the Multiple Communication Configurator (MC ToolKit). While both are made for in-field use, the MC Toolkit also can be ordered for use in intrinsically safe, Class I, Div. 1 environments.

The SCT 3000 Smartline[®] Configuration Toolkit provides an easy way to configure instruments using a personal computer as the configuration interface. The toolkit enables configuration of devices before shipping or prior to field installation. The SCT 3000 can operate in the off-line mode to pre-configure an unlimited number of devices. This database can then be loaded down-line during instrument commissioning.

Features

- Choice of linear or square root output conformity is a simple configuration selection.
- Direct digital integration with Experion PKS and other control systems provides local measurement accuracy to the system level without adding typical A/D and D/A converter inaccuracies.
- Unique piezoresistive sensor automatically compensates input for real-world temperature and static pressure variations.
- Added "smart" features include configuring lower and upper range values, simulating accurate analog output, and selecting preprogrammed engineering units for display.
- Smart transmitter capabilities with local or remote interfacing means significant manpower efficiency improvements in commissioning, start-up, and ongoing maintenance functions.
- ST 3000 transmitters feature full Dual-Seal certification based on ANSI/NFPA 70-202 and ANSI/ISA 12.27.01 requirements without the use of additional seal protection elements.
- ST 3000 transmitters are available fully compliant to SIL 2/3 requirements as a standard option.

Operating Conditions – All Models

Parameter	Reference Condition		Rated Condition		Operative Limits		Transportation and Storage	
	°C	°F	°C	°F	°C	°F	°C	°F
Ambient Temperature	25±1	77±2	-40 to 85	-40 to 185	-40 to 93	-40 to 200	-55 to 125	-67 to 257
Meter Body Temperature								
STA122/STA12L	25±1	77±2	See Figure 2		See Figure 2		-55 to 125	-67 to 257
STA140/STA14L	25±1	77±2	-40 to 80	-40 to 176	-40 to 80	-40 to 176	-55 to 125	-67 to 257
STA17L	25±1	77±2	-40 to 80	-40 to 176	-40 to 80	-40 to 176	-55 to 125	-67 to 257
Humidity %RH	10 to 55		0 to 100		0 to 100		0 to 100	
Vacuum Region - Minimum Pressure								
STA122/STA12L STA140/STA14L STA17L	See Figure 2. Operate within specifications above 25 mmHgA (33 mbarA). Short term exposure (2 hours at 70°C/158°F) to full vacuum will not result in damage.							
Supply Voltage, Current, and Load Resistance	Voltage Range: 10.8 to 42.4 Vdc at terminals Current Range: 3.0 to 21.8 mA Load Resistance: 0 to 1,440 ohms (as shown in Figure 3)							
Maximum Allowable Working Pressure (MAWP)⁴ (ST 3000 products are rated to Maximum Allowable Working Pressure. MAWP depends on Approval Agency and transmitter materials of construction.)	STA122/STA12L = 780 mmHgA, 1,040 mbarA STA140/STA14L = 500 psia, 34.47 barA STA17L = 3,000 psia, 206.8 bar A Units can withstand overpressure of 1.5x MAWP without damage.							

⁴ Consult factory for MAWP of ST 3000 transmitters with CSA approval.

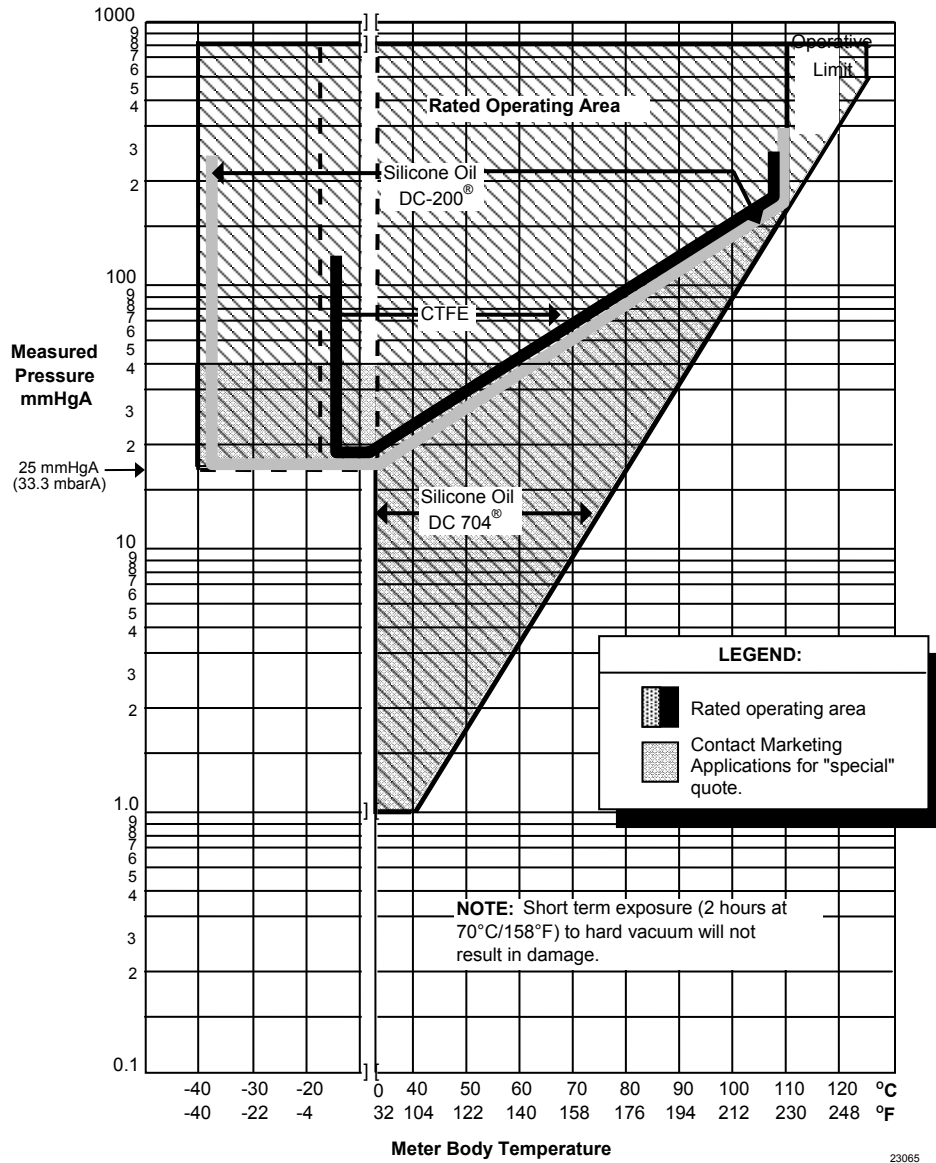

Figure 2 - Measured pressure versus meter body temperature chart for model STA122/STA12L

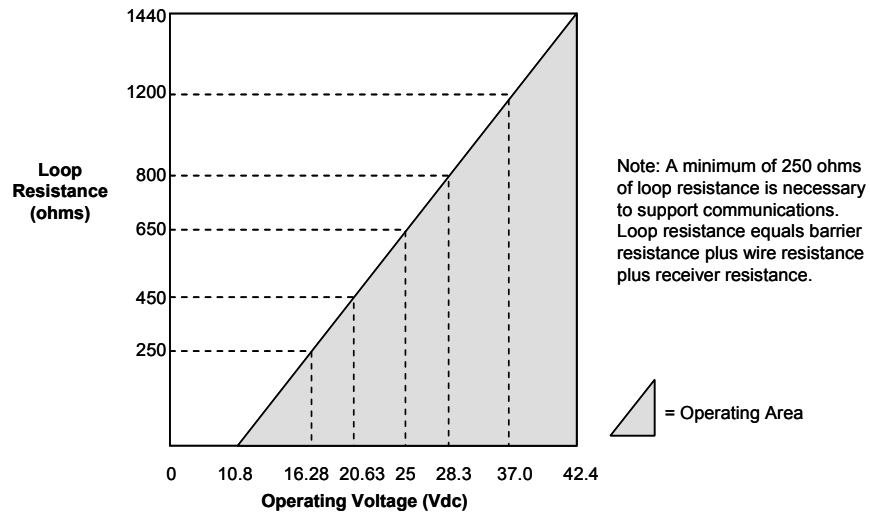

Figure 3 - Supply voltage and loop resistance chart

Performance Under Rated Conditions* - Model STA122 (0 to 780 mmHgA)

Parameter		Description
Upper Range Limit	mmHgA mbarA	780 (0°C/32°F is standard reference temperature for mmHg range.) 1,040
Minimum Span	mmHgA mbarA	50 67
Turndown Ratio		15 to 1
Zero Suppression		No limit except minimum span within 0 (absolute zero) to +100% URL.
Accuracy (Reference – Includes combined effects of linearity, hysteresis, and repeatability) <ul style="list-style-type: none"> Accuracy includes residual error after averaging successive readings. For FOUNDATION™ Fieldbus use Digital Mode specifications. For HART® use Analog Mode specifications. 		In Analog Mode: ±0.075% of calibrated span or upper range value (URV), whichever is greater, terminal based. For URV below reference point (90 mmHgA), accuracy equals: $\pm \left[0.025 + 0.05 \left(\frac{90 \text{ mmHgA}}{\text{span mmHgA}} \right) \right] \text{ or } \pm \left[0.025 + 0.05 \left(\frac{120 \text{ mbarA}}{\text{span mbarA}} \right) \right] \text{ in \% of span}$ In Digital Mode: ±0.0625% of calibrated span or upper range value (URV), whichever is greater, terminal based. For URV below reference point (90 mmHgA), accuracy equals: $\pm \left[0.0125 + 0.05 \left(\frac{90 \text{ mmHgA}}{\text{span mmHgA}} \right) \right] \text{ or } \pm \left[0.0125 + 0.05 \left(\frac{120 \text{ mbarA}}{\text{span mbarA}} \right) \right] \text{ in \% of span}$
Zero Temperature Effect per 28°C (50°F)		In Analog Mode: ±0.1125% of calibrated span. For URV below reference point (300 mmHgA), effect equals: $\pm \left[0.0125 + 0.10 \left(\frac{300 \text{ mmHgA}}{\text{span mmHgA}} \right) \right] \text{ or } \pm \left[0.0125 + 0.10 \left(\frac{400 \text{ mbarA}}{\text{span mbarA}} \right) \right] \text{ in \% of span}$ In Digital Mode: ±0.10% of calibrated span. For URV below reference point (180 mmHgA), effect equals: $\pm 0.10 \left(\frac{300 \text{ mmHgA}}{\text{span mmHgA}} \right) \text{ or } \pm 0.10 \left(\frac{400 \text{ mbarA}}{\text{span mbarA}} \right) \text{ in \% of span}$
Combined Zero and Span Temperature Effect per 28°C (50°F)		In Analog Mode: ±0.175% of calibrated span. For URV below reference point (300 mmHgA), effect equals: $\pm \left[0.075 + 0.10 \left(\frac{300 \text{ mmHgA}}{\text{span mmHgA}} \right) \right] \text{ or } \pm \left[0.075 + 0.10 \left(\frac{400 \text{ mbarA}}{\text{span mbarA}} \right) \right] \text{ in \% of span}$ In Digital Mode: ±0.15% of calibrated span. For URV below reference point (180 mmHgA), effect equals: $\pm \left[0.05 + 0.10 \left(\frac{300 \text{ mmHgA}}{\text{span mmHgA}} \right) \right] \text{ or } \pm \left[0.05 + 0.10 \left(\frac{400 \text{ mbarA}}{\text{span mbarA}} \right) \right] \text{ in \% of span}$

* Performance specifications are based on reference conditions of 25°C (77°F), 10 to 55% RH, and 316L Stainless Steel barrier diaphragm.

Performance Under Rated Conditions* - Model STA12L (0 to 780 mmHgA)

Parameter	Description
Upper Range Limit mmHgA mbarA	780 (0°C/32°F is standard reference temperature for mmHg range.) 1,040
Minimum Span mmHgA mbarA	50 67
Turndown Ratio	15 to 1
Zero Suppression	No limit except minimum span within 0 (absolute zero) to +100% URL.
Accuracy (Reference – Includes combined effects of linearity, hysteresis, and repeatability) <ul style="list-style-type: none"> • Accuracy includes residual error after averaging successive readings. • For FOUNDATION™ Fieldbus use Digital Mode specifications. • For HART® use Analog Mode specifications. 	In Analog Mode: ±0.075% of calibrated span or upper range value (URV), whichever is greater, terminal based. For URV below reference point (90 mmHgA), accuracy equals: $\pm \left[0.025 + 0.05 \left(\frac{90 \text{ mmHgA}}{\text{span mmHgA}} \right) \right] \text{ or } \pm \left[0.025 + 0.05 \left(\frac{120 \text{ mbarA}}{\text{span mbarA}} \right) \right] \text{ in \% of span}$ In Digital Mode: ±0.0625% of calibrated span or upper range value (URV), whichever is greater, terminal based. For URV below reference point (90 mmHgA), accuracy equals: $\pm \left[0.0125 + 0.05 \left(\frac{90 \text{ mmHgA}}{\text{span mmHgA}} \right) \right] \text{ or } \pm \left[0.0125 + 0.05 \left(\frac{120 \text{ mbarA}}{\text{span mbarA}} \right) \right] \text{ in \% of span}$
Zero Temperature Effect per 28°C (50°F)	In Analog Mode: ±0.1625% of calibrated span. For URV below reference point (300 mmHgA), effect equals: $\pm \left[0.0125 + 0.15 \left(\frac{300 \text{ mmHgA}}{\text{span mmHgA}} \right) \right] \text{ or } \pm \left[0.0125 + 0.15 \left(\frac{400 \text{ mbarA}}{\text{span mbarA}} \right) \right] \text{ in \% of span}$ In Digital Mode: ±0.15% of calibrated span. For URV below reference point (180 mmHgA), effect equals: $\pm 0.15 \left(\frac{300 \text{ mmHgA}}{\text{span mmHgA}} \right) \text{ or } \pm 0.15 \left(\frac{400 \text{ mbarA}}{\text{span mbarA}} \right) \text{ in \% of span}$
Combined Zero and Span Temperature Effect per 28°C (50°F)	In Analog Mode: ±0.25% of calibrated span. For URV below reference point (180 mmHgA), effect equals: $\pm \left[0.1 + 0.15 \left(\frac{300 \text{ mmHgA}}{\text{span mmHgA}} \right) \right] \text{ or } \pm \left[0.1 + 0.15 \left(\frac{400 \text{ mbarA}}{\text{span mbarA}} \right) \right] \text{ in \% of span}$ In Digital Mode: ±0.2125% of calibrated span. For URV below reference point (300 mmHgA), effect equals: $\pm \left[0.075 + 0.15 \left(\frac{300 \text{ mmHgA}}{\text{span mmHgA}} \right) \right] \text{ or } \pm \left[0.075 + 0.15 \left(\frac{400 \text{ mbarA}}{\text{span mbarA}} \right) \right] \text{ in \% of span}$

* Performance specifications are based on reference conditions of 25°C (77°F), 10 to 55% RH, and 316L Stainless Steel barrier diaphragm.

Performance Under Rated Conditions* - Model STA140/STA14L (0 to 500 psia)

Parameter	Description
Upper Range Limit	psia barA 500 35
Minimum Span	psia barA 5 0.35
Turndown Ratio	100 to 1
Zero Suppression	No limit except minimum span within 0 (absolute zero) to +100% URL.
Accuracy (Reference – Includes combined effects of linearity, hysteresis, and repeatability) <ul style="list-style-type: none"> Accuracy includes residual error after averaging successive readings. For FOUNDATION™ Fieldbus use Digital Mode specifications. For HART® use Analog Mode specifications. 	In Analog Mode: ±0.075% of calibrated span or upper range value (URV), whichever is greater, terminal based. For URV calibrated below reference point (20 psia), accuracy equals: $\pm \left[0.025 + 0.05 \left(\frac{20 \text{ psia}}{\text{span psia}} \right) \right] \text{ or } \pm \left[0.025 + 0.05 \left(\frac{1.4 \text{ barA}}{\text{span barA}} \right) \right] \text{ in \% of span}$ In Digital Mode: ±0.0625% of calibrated span or upper range value (URV), whichever is greater, terminal based. For URV calibrated below reference point (20 psia), accuracy equals: $\pm \left[0.0125 + 0.05 \left(\frac{20 \text{ psia}}{\text{span psia}} \right) \right] \text{ or } \pm \left[0.0125 + 0.05 \left(\frac{1.4 \text{ barA}}{\text{span barA}} \right) \right] \text{ in \% of span}$
Zero Temperature Effect per 28°C (50°F)	In Analog Mode: ±0.0625% of calibrated span. For URV below reference point (50 psia), effect equals: $\pm \left[0.0125 + 0.05 \left(\frac{\text{Ref. span **}}{\text{span psia}} \right) \right] \text{ or } \pm \left[0.0125 + 0.05 \left(\frac{\text{Ref. span **}}{\text{span barA}} \right) \right] \text{ in \% of span}$ In Digital Mode: ±0.05% of calibrated span. For URV below reference point (50 psia), effect equals: $\pm 0.05 \left(\frac{\text{Ref. span **}}{\text{span psia}} \right) \text{ or } \pm 0.05 \left(\frac{\text{Ref. span **}}{\text{span barA}} \right) \text{ in \% of span}$
Combined Zero and Span Temperature Effect per 28°C (50°F)	In Analog Mode: ±0.10% of calibrated span. For URV below reference point (50 psia), effect equals: $\pm \left[0.05 + 0.05 \left(\frac{\text{Ref. span **}}{\text{span psia}} \right) \right] \text{ or } \pm \left[0.05 + 0.05 \left(\frac{\text{Ref. span **}}{\text{span barA}} \right) \right] \text{ in \% of span}$ In Digital Mode: ±0.075% of calibrated span. For URV below reference point (50 psia), effect equals: $\pm \left[0.025 + 0.05 \left(\frac{\text{Ref. span **}}{\text{span psia}} \right) \right] \text{ or } \pm \left[0.025 + 0.05 \left(\frac{\text{Ref. span **}}{\text{span barA}} \right) \right] \text{ in \% of span}$

* Performance specifications are based on reference conditions of 25°C (77°F), 10 to 55% RH, and 316L Stainless Steel barrier diaphragm.

** Reference span Model STA140: 50 PSIA/ 3.5 barA, Model STA14L: 75 PSIA/ 5.25 barA

Performance Under Rated Conditions* - Model STA17L (0 to 3,000 psia)

Parameter	Description
Upper Range Limit psia barA	3,000 206.8
Minimum Span psia barA	30 2.07
Turndown Ratio	100 to 1
Zero Suppression	No limit except minimum span within 0 (absolute zero) to +100% URL.
Accuracy (Reference – Includes combined effects of linearity, hysteresis, and repeatability) <ul style="list-style-type: none"> Accuracy includes residual error after averaging successive readings. For FOUNDATION™ Fieldbus use Digital Mode specifications. For HART® use Analog Mode specifications. 	<p>In Analog Mode: ±0.075% of calibrated span or upper range value (URV), whichever is greater, terminal based. For URV calibrated below reference point (750 psia), accuracy equals:</p> $\pm \left[0.025 + 0.05 \left(\frac{750 \text{ psia}}{\text{span psia}} \right) \right] \text{ or } \pm \left[0.025 + 0.05 \left(\frac{51.7 \text{ barA}}{\text{span barA}} \right) \right] \text{ in \% of span}$ <p>In Digital Mode: ±0.0625% of calibrated span or upper range value (URV), whichever is greater, terminal based. For URV calibrated below reference point (750 psia), accuracy equals:</p> $\pm \left[0.0125 + 0.05 \left(\frac{750 \text{ psia}}{\text{span psia}} \right) \right] \text{ or } \pm \left[0.0125 + 0.05 \left(\frac{51.7 \text{ barA}}{\text{span barA}} \right) \right] \text{ in \% of span}$
Zero Temperature Effect per 28°C (50°F)	<p>In Analog Mode: ±0.1125% of calibrated span. For URV below reference point (500 psia), effect equals:</p> $\pm \left[0.0125 + 0.10 \left(\frac{500 \text{ psia}}{\text{span psia}} \right) \right] \text{ or } \pm \left[0.0125 + 0.10 \left(\frac{34.47 \text{ barA}}{\text{span barA}} \right) \right] \text{ in \% of span}$ <p>In Digital Mode: ±0.05% of calibrated span. For URV below reference point (500 psia), effect equals:</p> $\pm 0.10 \left(\frac{500 \text{ psia}}{\text{span psia}} \right) \text{ or } \pm 0.10 \left(\frac{34.47 \text{ barA}}{\text{span barA}} \right) \text{ in \% of span}$
Combined Zero and Span Temperature Effect per 28°C (50°F)	<p>In Analog Mode: ±0.175% of calibrated span. For URV below reference point (500 psia), effect equals:</p> $\pm \left[0.075 + 0.10 \left(\frac{500 \text{ psia}}{\text{span psia}} \right) \right] \text{ or } \pm \left[0.075 + 0.10 \left(\frac{34.47 \text{ barA}}{\text{span barA}} \right) \right] \text{ in \% of span}$ <p>In Digital Mode: ±0.075% of calibrated span. For URV below reference point (500 psia), effect equals:</p> $\pm \left[0.05 + 0.10 \left(\frac{500 \text{ psia}}{\text{span psia}} \right) \right] \text{ or } \pm \left[0.05 + 0.10 \left(\frac{34.47 \text{ barA}}{\text{span barA}} \right) \right] \text{ in \% of span}$

* Performance specifications are based on reference conditions of 25°C (77°F), 10 to 55% RH, and 316L Stainless Steel barrier diaphragm.

Performance Under Rated Conditions – All Models

Parameter	Description
Output (two-wire)	Analog : 4 to 20 mA (Normal signal range is ≥ 3.8 mA and ≤ 20.5 mA.) Digital communications: Honeywell DE mode, FOUNDATION™ Fieldbus or HART® protocol (selectable versions 5.x or 6.x available).
Supply Voltage Effect	0.005% span per volt.
Damping Time Constant	Adjustable from 0 to 32 seconds digital damping.
NAMUR NE 43 Compliance (Option “NE”)	Transmitter failure information is generated when the measuring information is invalid or no longer present. Failure information is transmitted as a current signal but outside the normal 4-20 mA measurement signal level. Transmitter failure values are: ≤ 3.6 mA and ≥ 21.0 mA. The normal signal range is ≥ 3.8 mA and ≤ 20.5 mA.
SIL 2/3 Compliance (Option “SL”)	SIL certified to IEC 61508 for non-redundant use in SIL 2 related Safety Systems (single use) and for redundant (multiple) use in SIL 3 Safety Systems through TÜV Nord Sys Tec GmbH & Co. KG under the following standards: IEC61508-1: 1998; IEC 61508-2: 2000; IEC61508-3: 1998.
Lightning Protection Option (Option “LP”)	Leakage Current: 10 microamps max. @ 42.4 VDC, 93°C Impulse Rating: 10/20 μ sec. 5,000 Amps (50 strikes) 10,000 Amps (20 strikes) (rise/decay) 10/1,000 μ sec. 250 Amps (1,000 strikes) 500 Amps (400 strikes)

Physical and Approval Bodies

Parameter	Description
Barrier Diaphragm Material	STA122 / STA140: 316L SS, Hastelloy [®] C-276 ² , Monel [®] 400 ³ STA12L / STA14L / STA17L: 316L SS, Hastelloy [®] and C276 ²
Process Head Material	STA122 / STA140: : 316 SS ⁴ , Carbon Steel (Zinc-plated) ⁵ , Monel [®] 400 ⁷ , Hastelloy [®] C-276 ⁶ STA12L / STA14L / STA17L: 316 SS ⁴
Head Gaskets	Viton [®] is standard. Teflon [®] is optional but not recommended for leak-proof service under full vacuum. Graphite is also optional – see MSG.
Meter Body Bolting	Carbon Steel (Zinc plated, standard) ⁵ or A286 SS (NACE) bolts and 304 SS (NACE) nuts for heads.
Mounting Bracket	Carbon Steel (Zinc-plated) ⁵ or Stainless Steel angle bracket or Carbon Steel flat bracket available.
Fill Fluid	Silicone DC [®] 200 oil or CTFE (Chlorotrifluoroethylene) Note that DC [®] 704 is available – Please contact Product Marketing.
Electronic Housing	Epoxy-Polyester hybrid paint. Low Copper-Aluminum. Meets NEMA 4X (watertight) and NEMA 7 (explosion proof). Stainless steel optional.
Process Connections	STA122 / STA140: 1/2-inch FNPT, 9/16-18 Aminco, DIN. STA12L / STA14L / STA17L: 1/2-inch F-NPT, 9/16-18 Aminco, DIN, ½ inch MNPT.
Wiring	Accepts up to 16 AWG (1.5 mm diameter).
Mounting	Can be mounted in virtually any position using the standard mounting bracket. Bracket is designed to mount on 2-inch (50 mm) vertical or horizontal pipe. See Figures 4 and 4a.
Dimensions	See Figures 5, 5a
Net Weight	Single Head Meter Body: 7.0 pounds (3.2 Kg) In-line Meter Body: 3.8 pounds (3.2 Kg)

² Hastelloy[®] C-276 or UNS N10276

³ Monel[®] 400 or UNS N04400

⁴ Supplied as 316 SS or as Grade CF8M, the casting equivalent of 316 SS.

⁵ Carbon Steel heads are zinc-plated and not recommended for water service due to hydrogen migration. For that service, use 316 stainless steel wetted Process Heads.

⁶ Hastelloy[®] C-276 or UNS N10276. Supplied as indicated or as Grade CW12MW, the casting equivalent of Hastelloy[®] C-276

⁷ Monel[®] 400 or UNS N04400. Supplied as indicated or as Grade M30C, the casting equivalent of Monel[®] 400

NOTE: Pressure transmitters that are part of safety equipment for the protection of piping (systems) or vessel(s) from exceeding allowable pressure limits, (equipment with safety functions in accordance with Pressure Equipment Directive 97/23/EC article 1, 2.1.3), require separate examination.

Certifications

	Type of Protection	Comm. Option	Field Parameters	Temp. Codes
FM ApprovalsSM	Explosionproof: Class I, Division 1, Groups A, B, C, D locations Dust Ignition Proof: Class II, III, Division 1, Groups E, F, G locations, Enclosure Type 4X	All	All	T5 Ta = 93°C
	Intrinsically Safe: Class I, II, III, Division 1, Groups A, B, C, D, E, F, G locations, Encl	4-20 mA / DE	Vmax = 42.4V Imax = 225mA Ci = 4.2nF Li = * Pi = 1.2W	T4 Ta = 93°C
		4-20 mA	Vmax = 30V Imax = 225mA Ci = 4.2nF Li = * Pi = 1.2W	T4 Ta = 93°C
	Intrinsically Safe: Class I, II, III, Division 1, Groups A, B, C, D, E, F, G locations; Class 1, Zone 0, AEx ia Group IIC, Enclosure Type 4X / IP 66/67	Fieldbus – Entity (Not FISCO)	Vmax = 32V Imax = 120mA Ci = 4.2nF Li = 0 Pi = 0.84W	T4 Ta = 40°C T3 Ta = 93°C
		Fieldbus – Entity (Not FISCO)	Vmax = 24V Imax = 250mA Ci = 4.2nF Li = 0 Pi = 1.2W	T4 Ta = 40°C T3 Ta = 93°C
		FISCO	Vmax = 17.5V Imax = 380mA Ci = 4.2nF Li = 0 Pi = 5.32W	T4 Ta = 40°C T3 Ta = 93°C
	Nonincendive: Class I, Division 2, Groups A, B, C, D locations, Enclosure Type 4X	4-20 mA / DE	Vmax = 42.4V Imax = 225mA Ci = 4.2nF Li = * Pi = 1.2W	T4 Ta = 93°C
		4-20 mA / HART	Vmax = 30V Imax = 225mA Ci = 4.2nF Li = * Pi = 1.2W	T4 Ta = 93°C
	Nonincendive: Class I, Division 2, Groups A, B, C, D; Suitable for: Class II, Division 2, Groups F&G; Class III, Division 2; Class I, Zone 2, Group IIC, Enclosure Type 4X / IP 66/67	Fieldbus – Entity (Not FNICO)	Vmax = 32V Imax = 120mA Ci = 4.2nF Li = 0 Pi = 0.84W	T4 Ta = 40°C T3 Ta = 93°C
		Fieldbus – Entity (Not FNICO)	Vmax = 24V Imax = 250mA Ci = 4.2nF Li = 0 Pi = 1.2W	T4 Ta = 40°C T3 Ta = 93°C
		FNICO	Vmax = 32V Ci = 4.2nF Li = 0	T4 Ta = 40°C T3 Ta = 93°C

*Li = 0 except Li = 150µH when Option ME, Analog Meter, is selected.

FM ApprovalsSM is a service mark of FM Global

	Type of Protection	Comm. Option	Field Parameters	Temp. Codes	
Canadian Standards Association (CSA)	Explosion Proof: Class I, Division 1, Groups B, C, D locations Dust Ignition Proof: Class II, III, Division 1, Groups E, F, G locations, Enclosure Type 4X	All	All	T4 Ta = 93°C	
	Intrinsically Safe: Class I, II, III, Division 1, Groups A, B, C, D, E, F, G locations, Enclosure Type 4X	4-20 mA / DE	Vmax = 42V Imax = 225mA Ci = 4.2nF Li = * Pi = 1.2W	T4 Ta = 93°C	
		4-20 mA / HART	Vmax = 42V Imax = 225mA Ci = 4.2nF Li = * Pi = 1.2W	T4 Ta = 93°C	
		Fieldbus – Entity (Not FISCO)	Vmax = 24V Imax = 250mA Ci = 4.2nF Li = 0 Pi = 1.2W	T4 Ta = 40°C T3 Ta = 93°C	
	Nonincendive: Class I, Division 2, Groups A, B, C, D locations, Enclosure Type 4X	4-20 mA / DE	Vmax = 42.4V Imax = 225mA Ci = 4.2nF Li = * Pi = 1.2W	T4 Ta = 93°C	
		4-20 mA / HART	Vmax = 30V Imax = 225mA Ci = 4.2nF Li = * Pi = 1.2W	T4 Ta = 93°C	
		Fieldbus – Entity (Not FNICO)	Vmax = 24V Imax = 250mA Ci = 4.2nF Li = 0 Pi = 1.2W	T4 Ta = 40°C T3 Ta = 93°C	
	Canadian Registration Number (CRN):	All ST 3000 models except STG19L, STG99L, STG170 and STG180 have been registered in all provinces and territories in Canada and are marked CRN: 0F8914.5C.			

	Type of Protection	Comm. Option	Field Parameters	Temp. Codes
IECEX International Electrotechnical Commission (LCIE)	Flameproof, Zone 1: Ex d IIC, Enclosure IP 66/67	All	All	T5 Ta = -50 to 93°C T6 Ta = -50 to 78°C
	Intrinsically Safe, Zone 0/1: Ex ia IIC, Enclosure IP 66/67	4-20 mA / DE	U _i = 30V I _i = 100mA C _i = 4.2nF L _i = * P _i = 1.2W	T4 Ta = -50 to 93°C T5 Ta = -50 to 85°C T6 Ta = -50 to 70°C
		4-20 mA / HART	U _i = 30V I _i = 100mA C _i = 4.2nF L _i = * P _i = 1.2W	T4 Ta = -50 to 93°C T5 Ta = -50 to 63°C T6 Ta = -50 to 48°C
		Fieldbus (Not FISCO)	U _i = 24V I _i = 250mA C _i = 4.2nF L _i = 0 P _i = 1.2W	T3 Ta = -50 to 93°C T4 Ta = -50 to 40°C

* L_i = 0 except L_i = 150µH when Option ME, Analog Meter, is selected.

	Type of Protection	Comm. Option	Field Parameters	Temp. Codes
SAEx (South Africa)	Flameproof, Zone 1: Ex d IIC, Enclosure IP 66/67	All	All	T5 Ta = -50 to 93°C T6 Ta = -50 to 78°C
	Intrinsically Safe, Zone 0/1: Ex ia IIC, Enclosure IP 66/67	4-20 mA / DE	U _i = 30V I _i = 100mA C _i = 4.2nF L _i = * P _i = 1.2W	T4 Ta = -50 to 93°C T5 Ta = -50 to 85°C T6 Ta = -50 to 70°C
		4-20 mA / HART	U _i = 30V I _i = 100mA C _i = 4.2nF L _i = * P _i = 1.2W	T4 Ta = -50 to 93°C T5 Ta = -50 to 63°C T6 Ta = -50 to 48°C
		Fieldbus (Not FISCO)	U _i = 24V I _i = 250mA C _i = 4.2nF L _i = 0 P _i = 1.2W	T3 Ta = -50 to 93°C T4 Ta = -50 to 40°C
	Multiple Marking: Flameproof, Zone 1: Ex d IIC, Enclosure IP 66/67 Intrinsically Safe, Zone 0/1: Ex ia IIC, Enclosure IP 66/67 NOTE: The user must determine the type of protection required for installation of the equipment. The user shall then check the box [√] adjacent to the type of protection used on the equipment certification nameplate. Once a type of protection has been checked on the nameplate, subsequently the equipment shall not be reinstalled using any of the other certification types.	4-20 mA / DE	U _i = 30V I _i = 100mA C _i = 4.2nF L _i = * P _i = 1.2W	T4 Ta = -50 to 93°C T5 Ta = -50 to 85°C T6 Ta = -50 to 70°C
		4-20 mA / HART	U _i = 30V I _i = 100mA C _i = 4.2nF L _i = * P _i = 1.2W	T4 Ta = -50 to 93°C T5 Ta = -50 to 63°C T6 Ta = -50 to 48°C
		Fieldbus (Not FISCO)	U _i = 24V I _i = 250mA C _i = 4.2nF L _i = 0 P _i = 1.2W	T3 Ta = -50 to 93°C T4 Ta = -50 to 40°C

* L_i = 0 except L_i = 150µH when Option ME, Analog Meter, is selected.

	Type of Protection	Comm. Option	Field Parameters	Temp. Codes
ATEX (LCIE)	Flameproof, Zone 0: ⊕ II 1 D, Ex tD Enclosure IP 66/67	All	All	A20 IP6X T95°C Ta = 93°C or T80°C Ta = 78°C
	Flameproof, Zone 1: ⊕ II 2 GD, Ex d IIC, Ex tD Enclosure IP 66/67	All	All	T5 Ta = -50 to +93°C T6 Ta = -50 to +78°C, A21 IP6X T95°C Ta = 93°C or T80°C Ta = 78°C
	Intrinsically Safe, Zone 0/1: ⊕ II 1 G, Ex ia IIC, Enclosure IP 66/67	4-20 mA / DE	Ui = 30V Ii = 100mA Ci = 4.2nF Li = * Pi = 1.2W	T4 Ta = -50 to 93°C T5 Ta = -50 to 85°C T6 Ta = -50 to 70°C
		4-20 mA / HART	Ui = 30V Ii = 100mA Ci = 4.2nF Li = * Pi = 1.2W	T4 Ta = -50 to 93°C T5 Ta = -50 to 63°C T6 Ta = -50 to 48°C
		Fieldbus (Not FISCO)	Ui = 24V Ii = 250mA Ci = 4.2nF Li = 0 Pi = 1.2W	T3 Ta = -50 to 93°C T4 Ta = -50 to 40°C
	Non-Sparking, Zone 2: ⊕ II 3 G, Ex nA IIC (Honeywell), Enclosure IP 66/67	4-20 mA / DE	Ui = 30V Ii = 100mA Ci = 4.2nF Li = * Pi = 1.2W	T4 Ta = -50 to 93°C T5 Ta = -50 to 85°C T6 Ta = -50 to 70°C
		4-20 mA / HART	Ui = 30V Ii = 100mA Ci = 4.2nF Li = * Pi = 1.2W	T4 Ta = -50 to 93°C T5 Ta = -50 to 63°C T6 Ta = -50 to 48°C
		Fieldbus (Not FNICO)	Ui = 24V Ii = 250mA Ci = 4.2nF Li = 0 Pi = 1.2W	T3 Ta = -50 to 93°C T4 Ta = -50 to 40°C
	Multiple Marking: Flameproof, Zone 1: ⊕ II 2 G, Ex d IIC Intrinsically Safe, Zone 0/1: ⊕ II 1 G, Ex ia IIC Non-Sparking, Zone 2: ⊕ II 3 G, Ex nA IIC NOTE: The user must determine the type of protection required for installation of the equipment. The user shall then check the box [√] adjacent to the type of protection used on the equipment certification nameplate. Once a type of protection has been checked on the nameplate, subsequently the equipment shall not be reinstalled using any of the other certification types.	4-20 mA / DE	Ui = 30V Ii = 100mA Ci = 4.2nF Li = * Pi = 1.2W	T4 Ta = -50 to 93°C T5 Ta = -50 to 85°C T6 Ta = -50 to 70°C
		4-20 mA / HART	Ui = 30V Ii = 100mA Ci = 4.2nF Li = * Pi = 1.2W	T4 Ta = -50 to 93°C T5 Ta = -50 to 63°C T6 Ta = -50 to 48°C
		Fieldbus (Not FISCO/FNICO)	Ui = 24V Ii = 250mA Ci = 4.2nF Li = 0 Pi = 1.2W	T3 Ta = -50 to 93°C T4 Ta = -50 to 40°C

* Li = 0 except Li = 150µH when Option ME, Analog Meter, is selected.

	Type of Protection	Comm. Option	Field Parameters	Temp. Codes
INMETRO (CERTUSP) Brazil	Flameproof, Zone 1: BR-Ex d IIC Enclosure IP 66/67	All	All	T5 Ta = -50 to 93°C T6 Ta = -50 to 78°C
	Intrinsically Safe, Zone 0/1: BR-Ex ia IIC Enclosure IP 66/67	4-20 mA / DE	U _i = 30V I _i = 100mA C _i = 4.2nF L _i = * P _i = 1.2W	T4 Ta = -50 to 93°C T5 Ta = -50 to 85°C T6 Ta = -50 to 70°C
		4-20 mA / HART	U _i = 30V I _i = 100mA C _i = 4.2nF L _i = * P _i = 1.2W	T4 Ta = -50 to 93°C T5 Ta = -50 to 63°C T6 Ta = -50 to 48°C
		Fieldbus (Not FISCO)	U _i = 24V I _i = 250mA C _i = 4.2nF L _i = 0 P _i = 1.2W	T3 Ta = -50 to 93°C T4 Ta = -50 to 40°C

*L_i = 0 except L_i = 150µH when Option ME, Analog Meter, is selected.

ST 3000 Pressure Transmitter Marine Certificate (MT Option)	This certificate defines the certifications covered for the ST 3000 Pressure Transmitter family of products, including the SMV 3000 Smart Multivariable Transmitter. It represents the compilation of the five certificates Honeywell currently has covering the certification of these products into marine applications. For ST 3000 Smart Pressure Transmitter and SMV 3000 Smart Multivariable Transmitter
	American Bureau of Shipping (ABS) - 2009 Steel Vessel Rules 1-1-4/3.7, 4-6-2/5.15, 4-8-3/13 & 13.5, 4-8-4/27.5.1, 4-9-7/13. Certificate number: 04-HS417416-PDA
	Bureau Veritas (BV) - Product Code: 389:1H. Certificate number: 12660/B0 BV
	Det Norske Veritas (DNV) - Location Classes: Temperature D, Humidity B, Vibration A, EMC B, Enclosure C. For salt spray exposure; enclosure of 316 SST or 2-part epoxy protection with 316 SST bolts to be applied. Certificate number: A-11476
	Korean Register of Shipping (KR) - Certificate number: LOX17743-AE001
	Lloyd's Register (LR) - Certificate number: 02/60001(E1) & (E2)

<p>European Pressure Equipment Directive (PED) (97/23/EC)</p>	<p>The ST 3000 Smart Pressure Transmitters are in conformity with the essential requirements of the Pressure Equipment Directive.</p> <p>Honeywell ST 3000 Smart Pressure Transmitters are designed and manufactured in accordance with the applicable portions of Annex I, Essential Safety Requirements, and sound engineering practices. These transmitters have no pressurized internal volume, or have a pressurized internal volume rated less than 200 bar (2,900 psig), and/or have a maximum volume of less than 0.1 liter (Article 3, 1.1.(a) first indent, Group 1 fluids). Therefore, these transmitters are not subject to the essential requirements of the directive 97/23/EC (PED, Annex I) and shall not have the CE mark applied.</p> <p>For transmitters rated > 200 bar (2,900 psig) < 1,000 bar (14,500 psig) Honeywell maintains a technical file in accordance with Annex III, Module A, (internal production control) when the CE mark is required. Transmitter Attachments: Diaphragm Seals, Process Flanges and Manifolds comply with Sound Engineering Practice.</p> <p>NOTE: Pressure transmitters that are part of safety equipment for the protection of piping (systems) or vessel(s) from exceeding allowable pressure limits, (equipment with safety functions in accordance with Pressure Equipment Directive 97/23/EC article 1, 2.1.3), require separate examination.</p> <p>A formal statement from TÜV Industry Service Group of TÜV America, Inc., a division of TÜV Süddeutschland, a Notified Body regarding the Pressure Equipment Directive, can be found at www.honeywell.com. A hard copy may be obtained by contacting a Honeywell representative.</p>
<p>CE Mark</p>	<p><i>Electro Magnetic Compatibility (EMC) (2004/108/EC)</i></p> <p>All Models: EN 50081-1: 1992; EN 50082-2:1995; EN 61326-1:1997 + A1, A2, and A3 – Industrial Locations</p>
<p>Measuring Instruments Directive (MID)</p>	<p>Measuring Instruments Directive (MID) (2004/22/EC) Applies only to STA17L (0-100 BAR) and STA14L (0-34.5 BAR) Temperature Range: Class 3 from -25 °C to + 55 °C</p>
<p>Recommended Frequency of Calibration</p>	<p>Honeywell recommends verifying the calibration of these devices once every four years.</p>
<p>Approved Manufacturing Locations</p>	<p>Honeywell Process Solutions - York, PA USA Honeywell (Tianjin) Limited – Tianjin, P.R. China Honeywell Automation India Ltd. – Pune 411013 India</p>

Foundation™ Fieldbus is a trademark of the Fieldbus Foundation.

HART® is a registered trademark of HART Communications Foundation.

Hastelloy® C-276 is a registered trademark of Haynes International.

Monel 400® is a registered trademark of Special Metals Corporation.

ST 3000® and Experion® are registered trademarks of Honeywell International Inc.

Viton® is a registered trademark of DuPont

Teflon® is a registered trademark of DuPont.

DC® 200 and DC® 704 are registered trademark of Dow Corning.

FM ApprovalsSM is a service mark of FM Global

Mounting

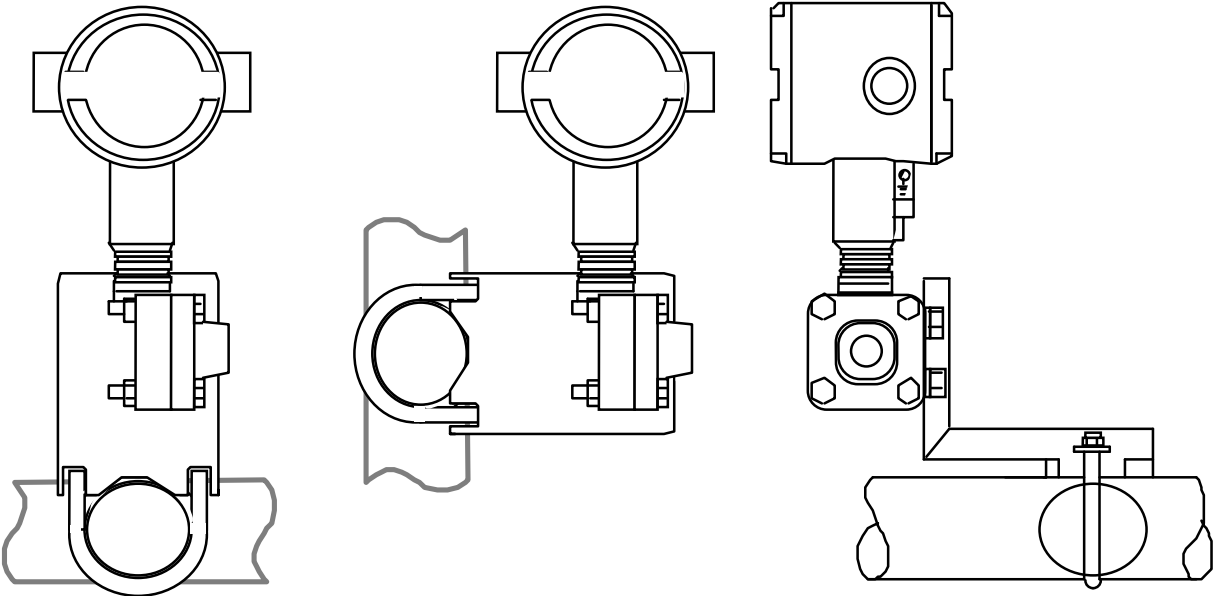

24267

Figure 3 - Examples of typical mounting positions for single-head models STA122 and STA140.

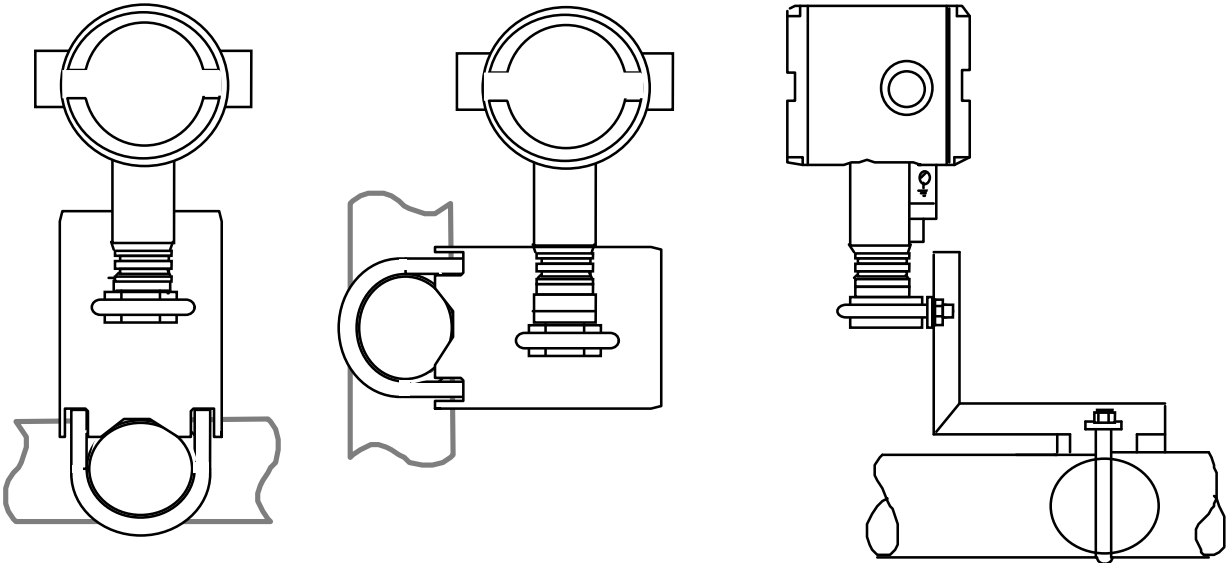

24268

Figure 4 - Examples of typical mounting positions for in-line models STA12L, STA14L and STA17L
Note that a mounting bracket is not required for in-line models.

Reference Dimensions

millimeters
inches

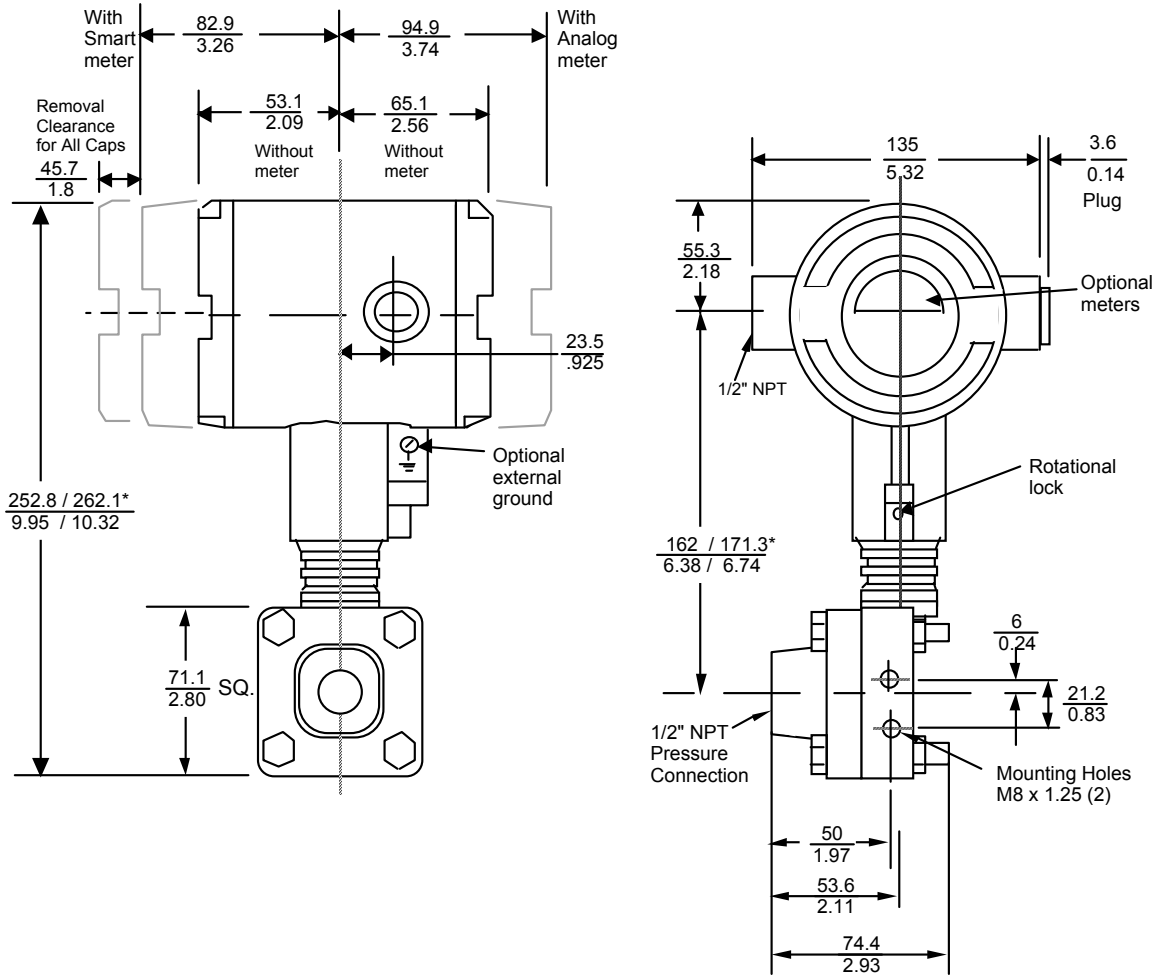

*Dimensions vary due to slight differences in electronics housing designs.

24269

Figure 5 - Typical mounting dimensions for single-head models STA122 and STA140 for reference

Reference Dimensions

millimeters
inches

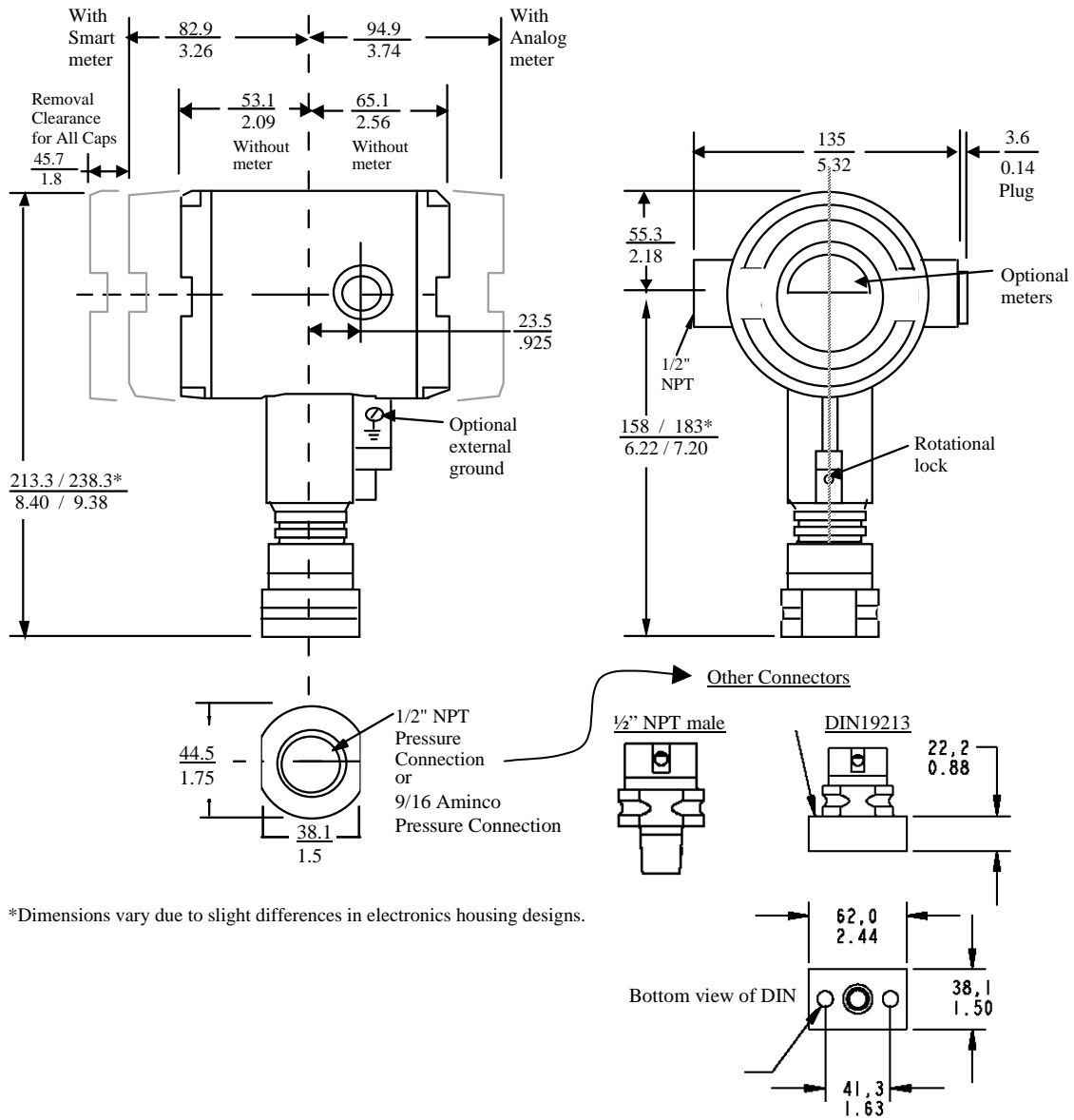

*Dimensions vary due to slight differences in electronics housing designs.

Figure 6 - Typical mounting dimensions for in-line models STA12L, STA14L and STA17L for reference.

Options

- **High Accuracy (Option HA)**
Extends applicable S100 models to $\pm 0.025\%$ analog reference accuracy.
- **Mounting Bracket (Options MB, MX, SB, SX, FB)**
The mounting bracket is available in either zinc-plated carbon steel or stainless steel and is suitable for horizontal or vertical mounting on a two inch (50 millimeter) pipe, as well as wall mounting. An optional flat mounting bracket is also available in carbon steel for two inch (50 millimeter) pipe mounting. An option also exists for Marine approved mounting brackets used with Marine certification options.
- **Indicating Meter (Options ME and SM)**
Two integral meter options are available. An analog meter (option ME) is available with a dual 0 to 10 square root and 0 to 100% linear scale. The Smart Meter (option SM) provides an LCD display for both analog and digital output and can be configured to display pressure in selected engineering units.
- **HART[®] Output Protocol (Options HC and H6)**
Optional electronic modules for the ST 3000 provide HART Protocol compatibility in either HART 5.x or 6.x formats. Transmitters with a HART Option are compatible with any HART enabled system that provides 5.x or 6.x format support.
- **Foundation[™] Fieldbus Output (Option FF)**
Equips transmitter with FF protocol for use in 31.25 kbit/s FF networks. See document 34-ST-03-72 for additional information on ST 3000 Fieldbus transmitters.
- **SIL2/SIL3 Certification (Option SL)**
This ST 3000 product is available for use with safety systems. With the SL option, we are fully certified to SIL 2 capability for single transmitters and SIL 3 capability for multiple transmitter use through TÜV Nord Sys Tec GmbH & Co. KG. We are in compliance with the following SIL standards:
 - IEC 61508-1: 1998;
 - IEC 61508-2: 2000;
 - IEC 61508-3: 1998
- **Lightning Protection (Option LP)**
A terminal block is available with circuitry that protects the transmitter from transient surges induced by nearby lightning strikes.
- **NAMUR NE43 Compliance (Option NE)**
This option provides software that meets the NAMUR NE43 requirements for failsafe software. Transmitter failure information is generated when the measuring information is no longer valid.

Transmitter failure values are ≤ 3.6 mA and ≥ 21.0 mA.
The normal ST 3000 ranges are ≤ 3.8 mA and ≥ 20.5 mA.
- **Write Protection (Options WP and WX)**
Provides the capability to hardwire write-protect installed transmitter configurations.
- **Stainless Steel Tagging (Option TG)**
Up to 30 characters can be added on the stainless steel nameplate mounted on the transmitter's electronics housing at no extra cost. A stainless steel wired on tag with additional data of up to 4 lines of 28 characters is also available. The number of characters for tagging includes spaces.
- **Transmitter Configuration (Options TC and FC)**
With Option TC, the factory can configure the analog, DE or HART transmitter's linear/square root extraction, damping time, LRV, URV and mode (analog/digital) and enter an ID tag of up to eight characters and scratchpad information as specified.

With Option FC, the Device ID, Transmitter Tag, Unit Level Node Address, Output Mode and Damping Time Constants can be specified.
- **Custom Calibration and ID in Memory (Option CC)**
The factory can calibrate any range within the scope of the transmitter's range and enter an ID tag of up to eight characters in the transmitter's memory.
- **Indicator Configuration (Option CI)**
Provides custom configuration of Smart Meters
- **Lifetime Warranty (Option WL)**
Extends limited 1-year warranty policy to 15 years for ST 3000 S100 pressure transmitters. See Honeywell Terms and Conditions.

Ordering information

For application assistance, current specifications, pricing, or name of the nearest Authorized Distributor, contact one of the offices below. Or, visit Honeywell on the World Wide Web at: <http://www.honeywell.com>.

ASIA PACIFIC

Control Products
Asia Pacific Headquarters
Phone: +(65) 6355-2828
Fax: +(65) 6445-3033

Asia Pacific Global Technical Support Field Instruments

Phone: +65 6580 3156
Fax: +65 6445-3033

Process Instruments

Phone: (603) 76950 4777
Fax: (603) 7958 8922

Australia

Honeywell Limited
Phone: +(61) 7-3846 1255
FAX: +(61) 7-3840 6481
Toll Free 1300-36-39-36
Toll Free Fax:
1300-36-04-70

China – PRC - Beijing

Honeywell China Inc.
Phone: +(86-10) 8458-3280
Fax: +(86-10) 8458-4650

China – PRC - Shanghai

Honeywell China Inc.
Phone: (86-21) 5257-4568
Fax: (86-21) 6237-2826

China – PRC - Chengdu

Honeywell China Inc.
Phone: +(86-28) 8678-6348
Fax: +(86-28) 8678-7061

China – PRC - Xi'an

Honeywell China Ltd - Xi'an.
Phone: +(86-29) 8833-7490
Fax: +(86-29) 8833-7489

China – PRC - Shenzhen

Honeywell China Inc.
Phone: +(86) 755-2518-1226
Fax: +(86) 755-2518-1221

Indonesia

PT Honeywell Indonesia
Phone: +(62) 21-535-8833
FAX: +(62) 21-5367 1008

India

Automation India Ltd.
Honeywell Ltd.
Phone: +(91) 5603-9400
Fax: +(91) 5603-9600

Japan

Honeywell Inc.
Phone: +(81) 3 6730 7150
Fax: +(81) 3 6730 7228

Malaysia

Honeywell Engineering
Sdn Bhd
Phone: +(60-3) 7950-4776
Fax: +(60-3) 7958-8922

New Zealand

Honeywell Limited
Phone: +(64-9) 623-5052
Fax: +(64-9) 623-5060
Toll Free (0800) 202-088

Philippines

Honeywell Systems
(Philippines) Inc.
Phone: +(63-2) 633-2830-31/
636 1661-62
Fax: +(63-2) 638-4013

Singapore

Honeywell Pte Ltd.
Phone: +(65) 6580 3278
Fax: +(65) 6445-3033

South Korea

Honeywell Korea Co Ltd
Phone: +(822) 799 6315
Fax: +(822) 792 9015

Thailand

Honeywell Systems
(Thailand) Ltd.
Phone: +(662) 693-3099
FAX: +(662) 693-3089

Taiwan R.O.C.

Honeywell Taiwan Ltd.
Phone: +(886-2) 2245-1000
FAX: +(886-2) 2245-3241

SE Asia Countries

see Honeywell Pte Ltd
(Singapore)
for:
Pakistan
Cambodia
Guam
Laos
Myanmar
Vietnam
East Timor

SE Asia Countries

see Honeywell Automation
India Ltd for:
Bangladesh
Nepal
Sri Lanka

EUROPE

Austria

Honeywell Austria GmbH
Phone: +43 (316)400123
FAX: +43 (316)40017

Belgium

Honeywell SA/NV
Phone: +32 (0) 2 728 24 07
FAX: +32 (0) 2 728 22 45

Bulgaria

Honeywell EOOD
Phone: +(359) 2 40 20 900
FAX: +(359) 2 40 20 990

Czech Republic

Honeywell spol. s.r.o.
Phone: +420 242 442 232
FAX: +420 242 442 131

Denmark

Honeywell A/S
Phone: +(45) 39 55 55 55
FAX: +(45) 39 55 55 58

Finland

Honeywell OY
Phone: +358 (0) 20752 2753
FAX: +358 (0) 20752 2751

France

Honeywell SA
Phone: +33 (0)1 60198075
FAX: +33 (0)1 60198201

Germany

Honeywell AG
Phone: +49 (69)8064-299
FAX: +49 (69)806497336

Hungary

Honeywell Kft.
Phone: +36-1-451 4300
FAX: +36-1-451 4343

Italy

Honeywell S.p.A.
Phone: +39 02 92146 307/
395
FAX: +39 0292146377

The Netherlands

Honeywell B.V.
Phone: +31 (0) 20 5656200
FAX: +31 (0) 20 5656210

Norway

Honeywell A/S
Phone: (45) 39 55 55 55

Poland

Honeywell Sp. zo.o
Phone: +48-22-6060900
FAX: +48-22-6060901

Portugal

Honeywell Portugal Lda
Phone: +351 21 424 5000
FAX: +351 21 424 50 99

Romania

Honeywell Bucharest
Phone: +40 (0) 21 2316437
FAX: +40 (0) 21 2316439

Russian Federation (RF),

Honeywell Field Solutions
Kievskaya str., 7,
Moscow 121059, Russia
Phone +7 (495) 796 98 60
Fax +7 (495) 797 99 64

Slovak Republic

Honeywell s.r.o.
Phone: +421-2-58247 410
FAX: +421-2-58247 415

Spain

Honeywell S.A.
Phone: +34 (0)91313 61 00
FAX: +34 (0)91313 61 30

Sweden

Honeywell AB
Phone: +(46) 8 775 55 00
FAX: +(46) 8 775 56 00

Switzerland

Honeywell AG
Phone: +41 18552448
FAX: +(41) 1 855 24 45

Turkey

Honeywell Turkey A.S.
Phone: +90 216 578 71 00
FAX: +90 216 575 66 35

Ukraine

Honeywell
Tel: +380-44-201 44 74
Fax: +380-44-201-44-75

United Kingdom

Honeywell Control Systems
Ltd.
Phone: +44 (0)1344 655251
FAX: +44 (0) 1344 655554

MIDDLE EAST

Abu Dhabi U A E

Middle East Headquarters
Honeywell Middle East Ltd.
Phone: +971 2 4041246
FAX: +971 2 4432536

Sultanate of Oman

Honeywell & Co Oman LLC
Phone: +968 24 701153/
Ext.33
FAX +968 24 787351

Saudia Arabia

Honeywell Turki Arabia Ltd
Jubail Office
Phone: +966-3-341-0140
Fax: +966-3-341-0216
Honeywell - ATCO
Dammam Office
Phone: 0096638304584
Fax: 0096638338059

Kuwait

Honeywell Kuwait KSC
Phone: +965 242 1327 to 30
Fax: +965 242 8315
and
Phone: +965 326 2934/1821
Fax: +965 326 1714

AFRICA

Mediterranean & African Distributors

Honeywell SpA
Phone: +39 (02) 250 10 604
FAX: +39 (02) 250 10 659

South Africa (Republic of) and sub saharan

Honeywell Southern Africa
Honeywell S.A. Pty. Ltd.
Phone: +27 11 6958000
FAX +27 118051504

NORTH AMERICA

Canada

Honeywell LTD
Phone: 1-800-737-3360
FAX: 1-800-565-4130

USA

Honeywell Process Solutions,
Phone: 1-800-423-9883
Or 1-800-343-0228
Email: ask-ssc@honeywell.com

SOUTH AMERICA

Argentina

Honeywell S.A.I.C.
Phone: +(54-11) 4383-3637
FAX: +(54-11) 4325-6470

Brazil

Honeywell do Brasil & Cia
Phone: +(55-11) 7266-1900
FAX: +(55-11) 7266-1905

Chile

Honeywell Chile, S.A.
Phone: +(56-2) 233-0688
FAX: +(56-2) 231-6679

Mexico

Honeywell S.A. de C.V.
Phone: +(52) 55 5259-1966
FAX: +(52) 55 5570-2985

Puerto Rico

Honeywell Inc.
Phone: +(809) 792-7075
FAX: +(809) 792-0053

Trinidad

Honeywell Inc.
Phone: +(868) 624-3964
FAX: +(868) 624-3969

Venezuela

Honeywell CA
Phone: +(58-2) 238-0211
FAX: +(58-2) 238-3391

Specifications are subject to change without notice.

Model Selection Guides are subject to change and are inserted into the specifications as guidance only. Prior to specifying or ordering a model check for the latest revision Model Selection Guides which are published at: <http://hpsweb.honeywell.com/Cultures/en-US/Products/Instrumentation/ProductModelSelectionGuides/default.htm>

Model Selection Guide



34-ST-16U-03
Issue 57
Page 1 of 4

**ST 3000 Smart Transmitter
Gage Pressure (GP) &
Absolute Pressure (AP)
Series 100**

Model Selection Guide



Instructions

- Select the desired Key Number. The arrow to the right marks the selection available.
- Make one selection from each Table (I, II and IV) using the column below the proper arrow.
- Select as many Table III options as desired plus a required communications option selection.
- A (●) denotes unrestricted availability. A letter denotes restricted availability.
- Restrictions follow Table IV.

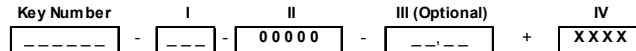

KEY NUMBER

	Design	Span	Selection	Availability					
Gage Pressure	Single Head	0-5 to 0-500 psi / 0-0.34 to 0-35 bar	STG140		↓				
		0-30 to 0-3,000 psi / 0-2.1 to 0-210 bar	STG170		↓				
		0-60 to 0-6,000 psi / 0-4.1 to 0-420 bar	STG180			↓			
	In-Line	0-5 to 0-500 psi / 0-0.34 to 0-35 bar	STG14L				↓		
		0-30 to 0-3,000 psi / 0-2.1 to 0-210 bar	STG17L				↓		
		0-60 to 0-6,000 psi / 0-4.1 to 0-420 bar	STG18L				↓		
Absolute Pressure	Single Head	0-50 to 0-780 mm HgA / 0-67 to 0-1,040 mbarA	STA122	↓					
		0-5 to 0-500 psi/0-0.34 to 0-35 bar absolute	STA140		↓				
	In-Line	0-50 to 0-780 mm HgA / 0-67 to 0-1,040 mbarA	STA12L						↓
		0-5 to 0-500 psia / 0-0.34 to 0-35 barA	STA14L					↓	
		0-30 to 0-3,000 psia / 0-2.1 to 0-210 barA	STA17L					↓	

Important Note: Base STG and STA models no longer include a default communications option. All units now require the selection of a communication option from Table III (AN, DE, HC, H6 or FF).

TABLE I - METER BODY

	Wetted Process Heads / Bonnet	Vent/Drain Valves	Barrier Diaphragms	Selection						
Materials of Construction	Carbon Steel ¹	-	316L SS	A__	●	●	●	●		
	Carbon Steel ¹	-	Hastelloy® C-276 ³	B__	●	●	●	●		
	Carbon Steel ¹	-	Monel 400® ⁴	C__	19	19	19	19		
	316 SS ⁵	-	316L SS	E__	●	●	●	●		
	*	-	316L SS	E__					●	●
	316 SS ⁵	-	Hastelloy® C-276 ³	F__	●	●	●	●		
	*	-	Hastelloy® C-276 ³	F__					●	●
	316 SS ⁵	-	Monel 400® ⁴	G__	19	19	19	19		
	Hastelloy® C-276 ^{3,6}	-	Hastelloy® C-276 ³	J__	●	●	●	●		
Monel 400® ⁷	-	Monel 400® ⁴	L__	19	19	19	19			
Fill Fluid	Silicone DC®200 ⁸			_1_	●	●	●	●	●	●
	CTFE (Halocarbon 6.3)			_2_	●	●	●	●	●	●
	CTFE (MO-10)			_4_	●					●
Process Connection Configuration	9/16" - 18 Aminco			_A_	●	●	●	●	●	●
	1/2 NPT (female)			_G_	●	●	●	●	●	●
	1/2 NPT (male)			_H_					●	●
	DIN 19213			_D_					●	●

¹ Carbon Steel heads are zinc-plated and not recommended for water service due to hydrogen migration. For that service, use 316 stainless steel Wetted Process Heads.
³ Hastelloy® C-276 or UNS N10276
⁴ Monel 400® or UNS N04400
⁵ Supplied as 316 SS or as Grade CF8M, the casting equivalent of 316 SS.
⁶ Supplied as indicated or as Grade CW12MW, the casting equivalent of Hastelloy® C-276
⁷ Supplied as indicated or as Grade M30C, the casting equivalent of Monel 400®
⁸ Use DC®704 option when the STA122 or STA12L will be operating below 50mm HgA, see Fig. 2 in Specification 34-ST-03-65.
 * STG1_L has 316L SS process interface.

TABLE III - OPTIONS (continued)

Approval Body	Approval Type	Location or Classification	Selection	STG180	STG170	STG140	STA140	STA122	STG14L	STA14L/17L, STG17L/18L	STG19L	STA12L
Canadian Standards Association (CSA)	Explosion Proof	Class I, Div. 1, Groups B,C,D	2J	24	24	24	24	24	24	24	4	24
	Dust-Ignitionproof	Class II, III, Div. 1, Groups E,F,G		24	24	24	24	24	24	24	24	24
	Intrinsically Safe	Class I, II, III, Div. 1, Groups A,B,C,D,E,F,G		24	24	24	24	24	24	24	24	24
IECEX	Flameproof, Zone 1	Ex d IIC; T5 (Ta = -40 to +93°C), T6 (Ta = -40 to +78°C)	CA	24	24	24	24	24	24	24	24	24
	Intrinsically Safe, Zone 0/1	Ex ia IIC; T3, T4, T5, T6 See Spec for detailed temperature codes by Communications option		24	24	24	24	24	24	24	24	24
SAEx (South Africa)	Intrinsically Safe, Zone 0/1	Ex ia IIC T4, T5, T6	Z2	•	•	•	•	•	•	•	•	•
	Flameproof, Zone 1	EX d IIC T5, T6 Enclosure IP 66/67	ZD	•	•	•	•	•	•	•	•	•
	Multiple Marking ¹¹ Int. Safe, Zone 0/1, or Flameproof, Zone 1	Ex ia IIC T4, T5, T6 Ex d IIC T5, T6 Enclosure IP 66/67	ZA	•	•	•	•	•	•	•	•	•
CERTUSP INMETRO (Brazil)	Flameproof, Zone 1	BR- Ex d IIC T5, T6	6D	•	•	•	•	•	•	•	•	•
	Intrinsically Safe, Zone 0/1	BR- Ex ia IIC; T4, T5, T6 (See CERTUSP certificate for detailed temperature codes by Communications option)	6S	•	•	•	•	•	•	•	•	•

¹⁰ See ATEX installation requirements in the ST 3000 User's Manual

¹¹ The user must determine the type of protection required for installation of the equipment. The user shall then check the box [x] adjacent to the type of protection used on the equipment certification nameplate. Once a type of protection has been checked on the nameplate, subsequently the equipment shall not be reinstalled using any of the other certification types.

TABLE IV

Factory Identification	Selection											
XXXX	•	•	•	•	•	•	•	•	•	•	•	•

RESTRICTIONS

Restriction Letter	Available Only With		Not Available With	
	Table	Selection	Table	Selection
b	Select only one option from this group			
d	I	A __, E __		
e	III	SM		
f			III	2J
g			III	SL
h	I	_ 2 _		
i	III	1C or 2J		
m			III	STA12L, STA14L, ME, FF
n			III	1C, 2J
o	III	CR		
p	III	HC or H6 and WP	III	FF, WX
r	III	FISCO/FNICO compliance available only with 1C	III	TC, ME, or FISCO/FNICO compliance not available 2J, 3C, 3N, 33, 3S, CA, Z2, ZD, ZA, 6D & 6S
w	I	E _ G, F _ G, G _ G		
x	III	FF, SM	Key#	STA12L, STA14L
z			I	B __, F __, J __
2	III	MX, SX	III	FB, MB, SB
4	III	This approval code requires the selection of a certified conduit plug: A5, A6 or A7	III	No CRN Number available
15			III	FF
19			III	F7, FG
21	III	FF		
22	III	SL		
24	III	This approval code requires the selection of a certified conduit plug: A5, A6 or A7		

Ordering Example: STG140-A1A-00000-HC,NE,3H+XXXX

Hastello® is a registered trademark of Haynes International
 Monel 400® is a registered trademark of Special Metals Corporation.
 HART® is a registered trademark of HART Communication Foundation.
 FOUNDATION™ Fieldbus is a trademark of Fieldbus Foundation.
 Viton® is a registered trademark of DuPont Performance Elastomers.
 Teflon® is a registered trademark of DuPont.
 DC®200 and DC®704 are registered trademarks of Dow Corning.

For More Information

Learn more about how Honeywell's ST 3000 Smart Pressure Transmitters can increase performance, reduce downtime and decrease configuration costs, visit our website www.honeywell.com/ps or contact your Honeywell account manager.

Honeywell Process Solutions

1860 West Rose Garden Lane
Phoenix, AZ 85027
1-800-423-9883 or 1-800-343-0228

www.honeywell.com/ps

34-ST-03-61
June 2011
© 2010 Honeywell International Inc.

The Honeywell logo is displayed in a bold, red, sans-serif font.